

2018
Edição nº4

RODOWESSLER®

REFERÊNCIA EM PEÇAS PARA IMPLEMENTOS



CATÁLOGO DE PEÇAS



Indústria - Comércio - Serviços

(11) 2431 - 5300

www.rodowessler.com.br



Loja Guarulhos



Loja Campinas

HISTÓRICO RODOWESSLER

Iniciando suas atividades em 1992, a Wessler Transportes Ltda., começou atuando no segmento de transporte de cargas em geral e posteriormente no segmento de Reformas de Equipamentos Rodoviários. O objetivo inicial era atender as necessidades das Empresas de Transportes nas regiões de Guarulhos e São Paulo.

Com competência, comprometimento, profissionalismo e uma oficina bem equipada, a Wessler conquistou o seu espaço, chegando a atender grandes empresas no setor de transporte na época.

Observando a grande demanda de serviços e a exigência de constante troca de peças que as reformadoras e montadoras tinham, principalmente as suas dificuldades de conseguir peças de reposição para equipamentos rodoviários, o diretor da Wessler inaugurou em 2001 a RODOWESSLER Peças e Serviços, uma Loja especializada no comércio de peças de reposição das principais marcas de Implementos Rodoviários, dentre os seguintes equipamentos: Furgões Duralumínio (Baús), Furgões Lonados (Siders) e Carrocerias para Transportes de Bebida.

Desde 1996 a RODOWESSLER trabalha com Portas Roll-Up, porém em 2003, visando uma melhor segmentação, a RODOWESSLER lançou o Depto. Portas especiais: WPR - Wessler Portas Roll-Up., Um segmento dentro da RODOWESSLER que agrega todas as conveniências e praticidades de um produto com inovação, para atender a logística das Empresas de Transportes.

Após cinco anos de um próspero crescimento, atendendo sempre a grande demanda das variedades de peças para cada segmento, a RODOWESSLER transferiu suas instalações para uma área de 12 mil m², situada na cidade de Guarulhos - São Paulo.

Com infra-estrutura e logística de qualidade, a RODOWESSLER aperfeiçoou-se para um atendimento "just in time", possuindo um estoque completo de peças e acessórios, bem como uma equipe de profissionais preparados para atender de modo eficaz as necessidades dos nossos clientes.

Em 2012, visando uma maior competitividade no mercado, a RODOWESSLER incluiu a atividade Industrial. Com a grande capacidade produtiva, aumentou a linha e qualidade dos produtos oferecidos aos clientes, no melhor custo-benefício.

No ano de 2015, a Rodowessler deu início a exportação de seus produtos para todos os países do Mercosul, com atendimento personalizado para compreender as necessidades e particularidades de cada país.

Em 2016 foram inauguradas duas lojas para mantermos mais proximidade com os clientes e também para desburocratização nos processos de venda e entrega dos produtos.

Nossos produtos passam por rigoroso controle de qualidade, garantindo assim confiabilidade aos clientes RODOWESSLER.

Todo esse esforço, é para atender todos os clientes, com uma grande diversidade de peças multimarca para Implementos Rodoviários, sempre atuando de forma Comprometida, Atenciosa e Inovadora.

RODOWESSLER, referência em peças para implementos

ÍNDICE GERAL

<i>FURGÃO DURALUMÍNIO</i>	<i>PAG.005</i>
<i>FURGÃO FRIGORÍFICO</i>	<i>PAG.023</i>
<i>ACESSÓRIOS PARA FURGÃO</i>	<i>PAG.024</i>
<i>TRAVA CARGAS</i>	<i>PAG.026</i>
<i>FURGÃO LONADO</i>	<i>PAG.029</i>
<i>COLUNAS MÓVEIS</i>	<i>PAG.036</i>
<i>TRILHOS DE SIDER</i>	<i>PAG.038</i>
<i>CATRACAS</i>	<i>PAG.039</i>
<i>LONAS DE SIDER</i>	<i>PAG.040</i>
<i>TRANSPORTE DE VESTUÁRIOS</i>	<i>PAG.044</i>
<i>PISOS ROLETADOS E DIVISÓRIAS</i>	<i>PAG.045</i>
<i>PISO DUPLO (DOUBLE DECK)</i>	<i>PAG.046</i>
<i>PORTAS ROLL UP</i>	<i>PAG.047</i>
<i>PORTAS CONVENCIONAIS</i>	<i>PAG.049</i>
<i>PORTAS FRIGORÍFICAS</i>	<i>PAG.064</i>
<i>PORTAS PARA CARROCERIAS DE BEBIDAS</i>	<i>PAG.067</i>
<i>BASES SOBRE CHASSIS</i>	<i>PAG.072</i>
<i>BASE SEMI REBOQUE</i>	<i>PAG.074</i>
<i>PROTETOR CICLISTA</i>	<i>PAG.076</i>
<i>PEÇAS PARA CARGA SECA</i>	<i>PAG.077</i>
<i>PEÇAS PARA GRANELEIRO</i>	<i>PAG.077</i>
<i>AMARRAÇÃO DE CARGAS</i>	<i>PAG.077</i>
<i>ELEMENTOS DE FIXAÇÃO</i>	<i>PAG.081</i>
<i>LANTERNAS E FIOS</i>	<i>PAG.082</i>



Nenhuma parte desta publicação pode ser reproduzida ou publicada por meios de impressão, fotocópia, microfilme, ou qualquer outra forma, sem autorização por escrito da RODOWESSLER PEÇAS E SERVIÇOS EIRELI - Lei 9.610/1998.

SERVIÇOS RODOWESSLER

**A RODOWESSLER SEMPRE ESTÁ DE PORTAS ABERTAS
PARA NOVOS NEGÓCIOS:**

**LOCAÇÕES, COMPRAS E VENDAS
DE USADOS**



**Executamos serviços terceirizados com a matéria prima
(chapas, bobinas) fornecida pelo cliente.**

FRISAGEM DE CHAPAS

Entre em contato para saber as
formas de fornecimento

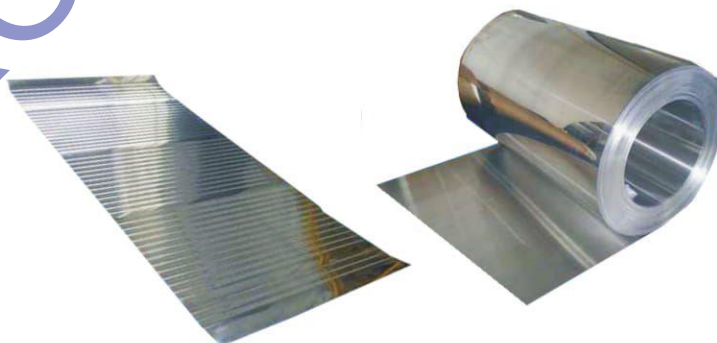

(11) 2431-5300

RODOWESSLER

Peças para Implementos Rodoviários

Site: www.rodowessler.com.br
e-mail: vendas@rodowessler.com.br

Figuras e Fotos Meramente Ilustrativas.

(11) 2431-5300

RODOWESSLER®

REFERÊNCIA EM PEÇAS PARA IMPLEMENTOS

FURGÃO DURALUMÍNIO

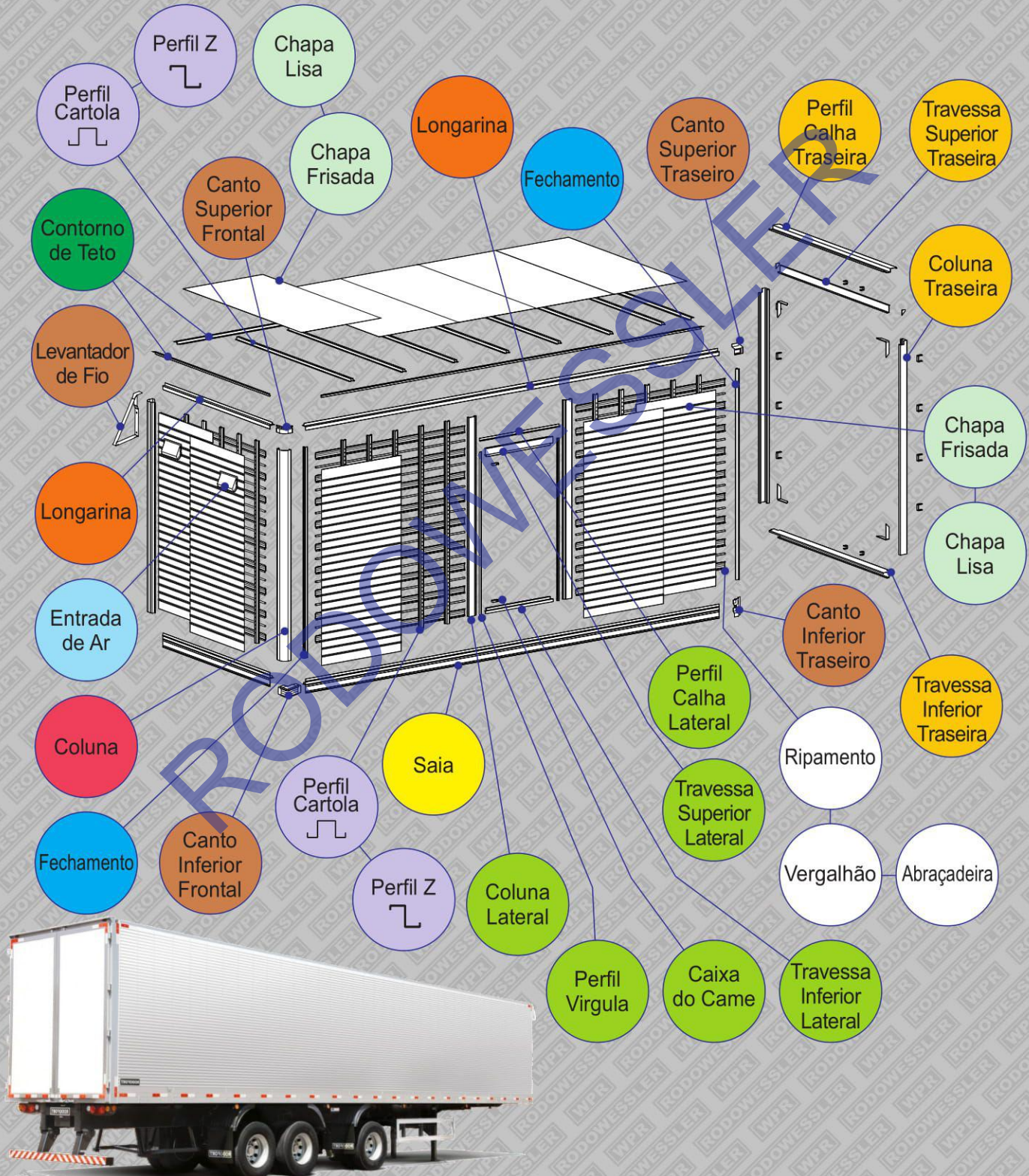

FURGÃO DURALUMÍNIO

A
N
T
O
N
I
R
O
D
O
F
O
R
T

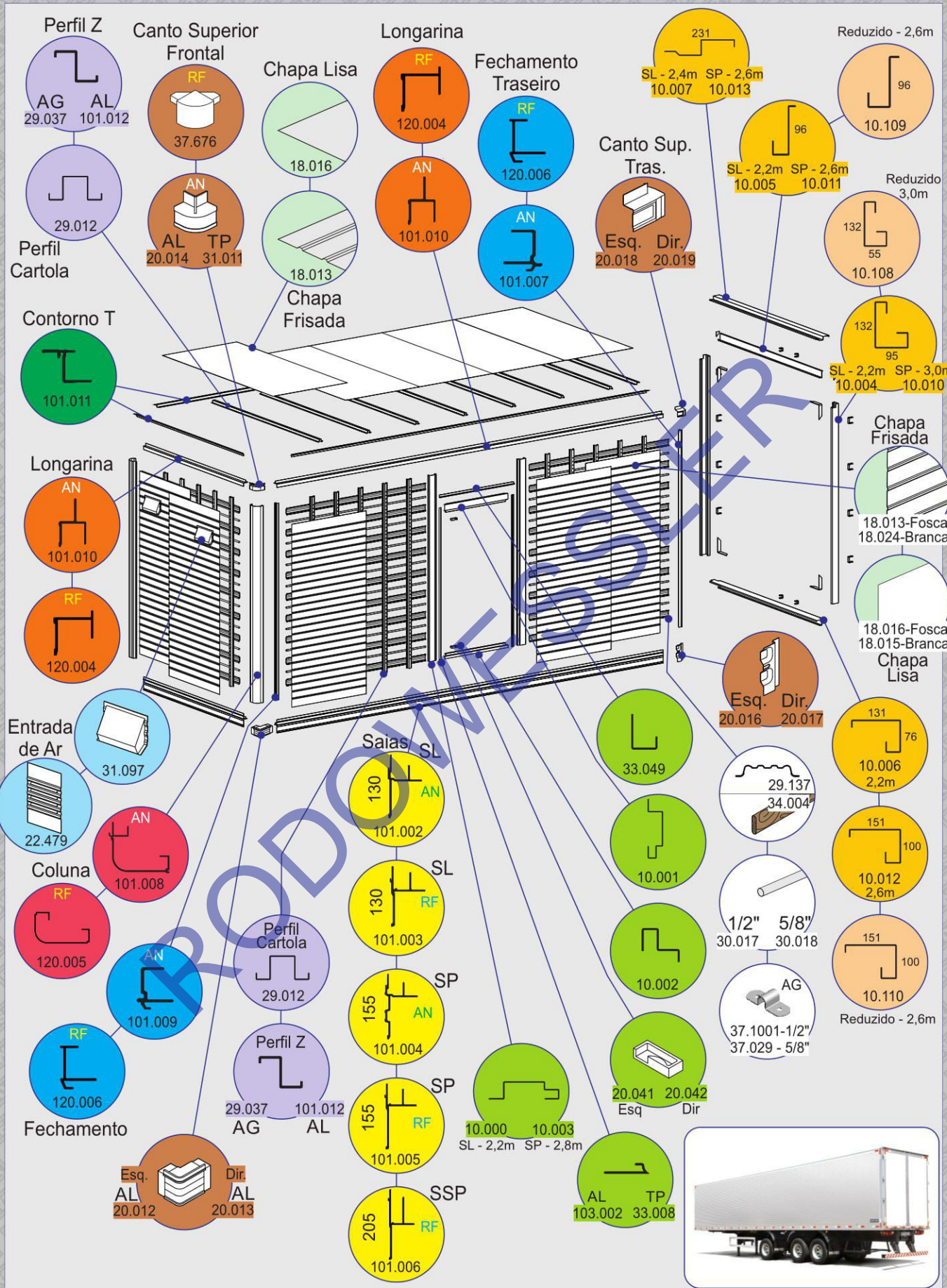

Figuras e Fotos Meramente Ilustrativas.



FURGÃO DURALUMÍNIO

B
E
R
T
O
L
I
N
I
*
C
A
R
G
O
*
V
A
N
*
G
A
L
E
G
O

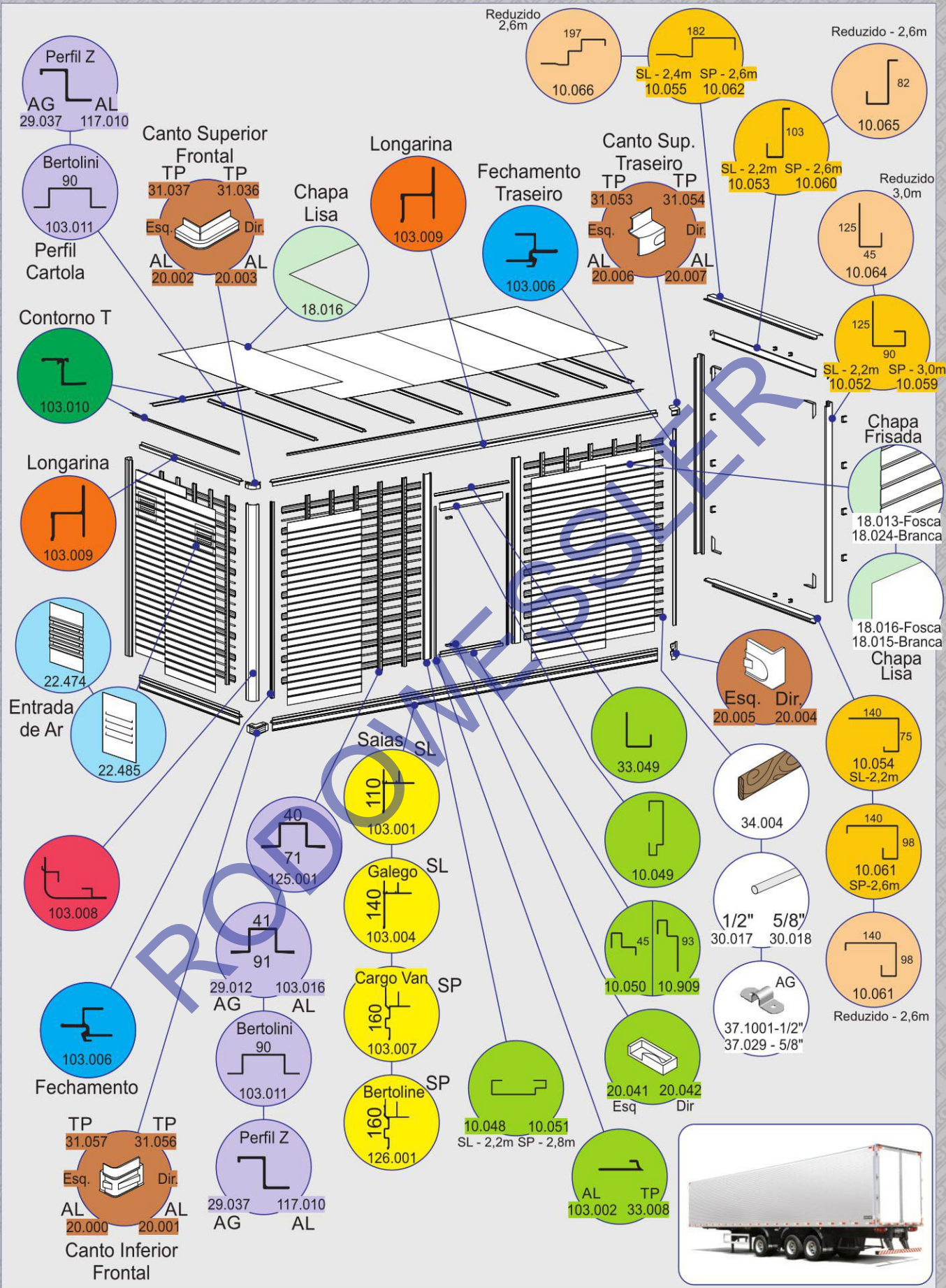

Figuras e Fotos Meramente Ilustrativas.

FURGÃO DURALUMÍNIO

CARBUNO

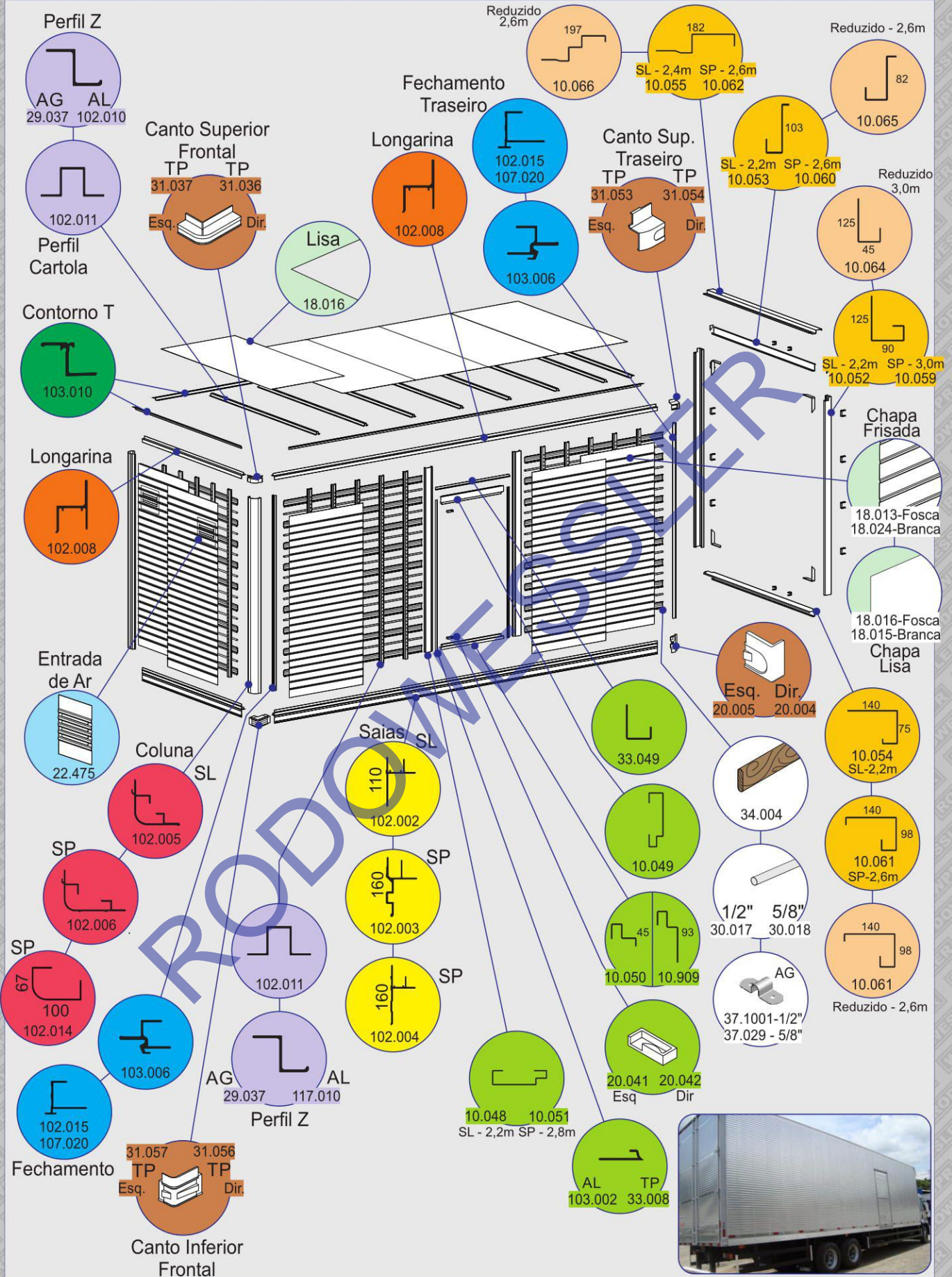

Figuras e Fotos Meramente Ilustrativas.

FURGÃO DURALUMÍNIO

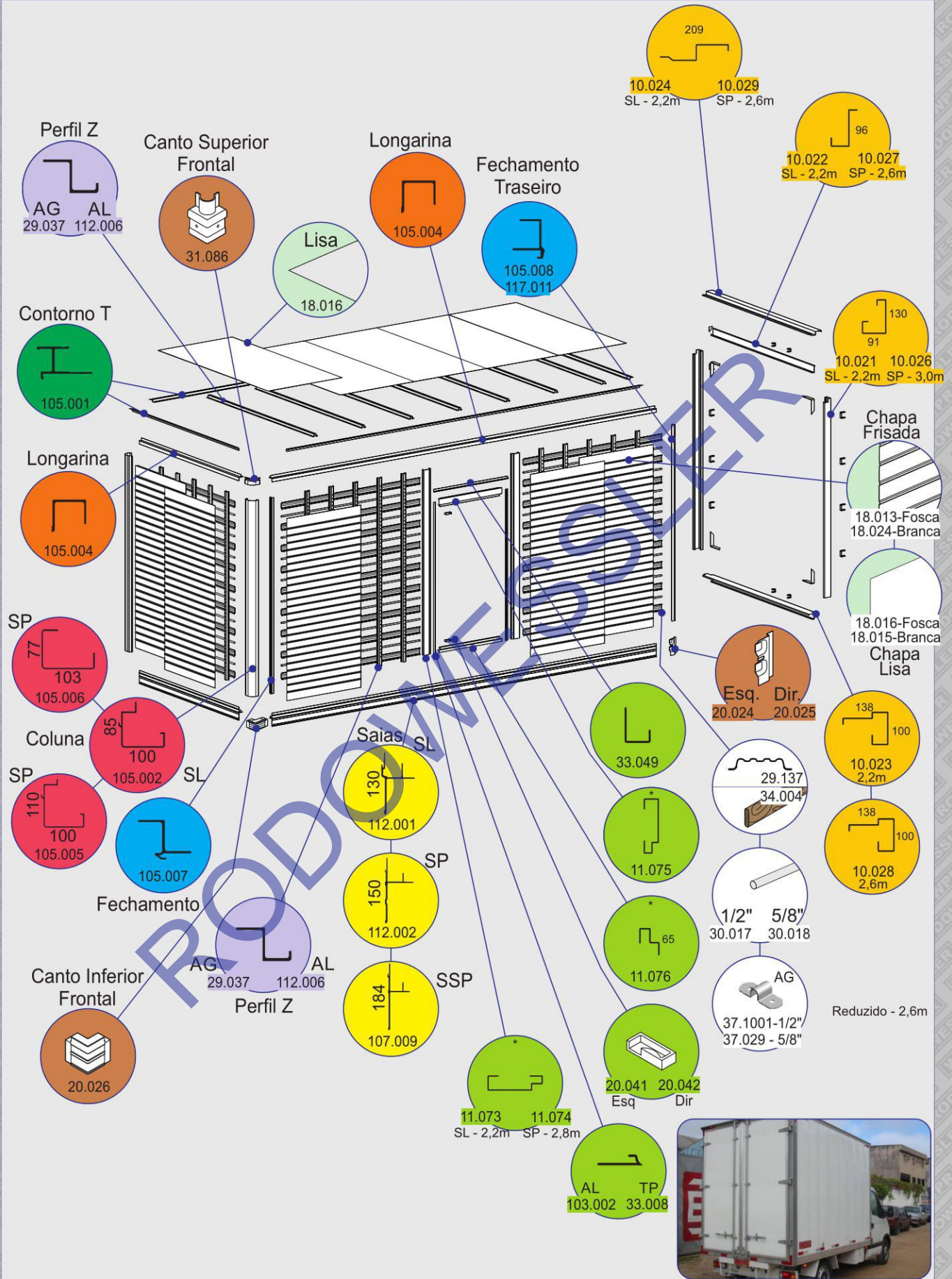

E
D
A
R
P

Figuras e Fotos Meramente Ilustrativas.

FURGÃO DURALUMÍNIO

F A C H I N H O S

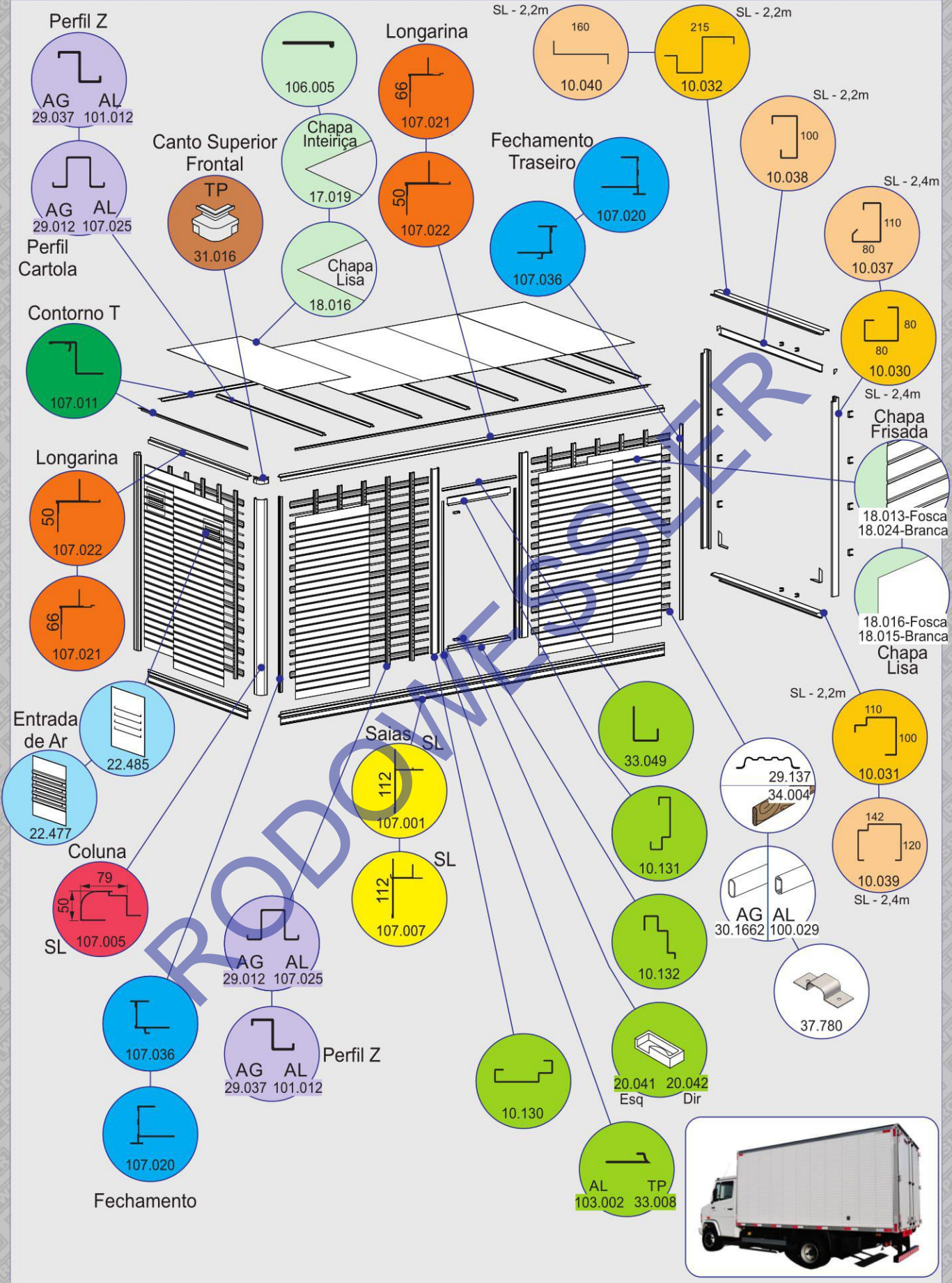

Figuras e Fotos Meramente Ilustrativas.



FURGÃO DURALUMÍNIO

FURCAR

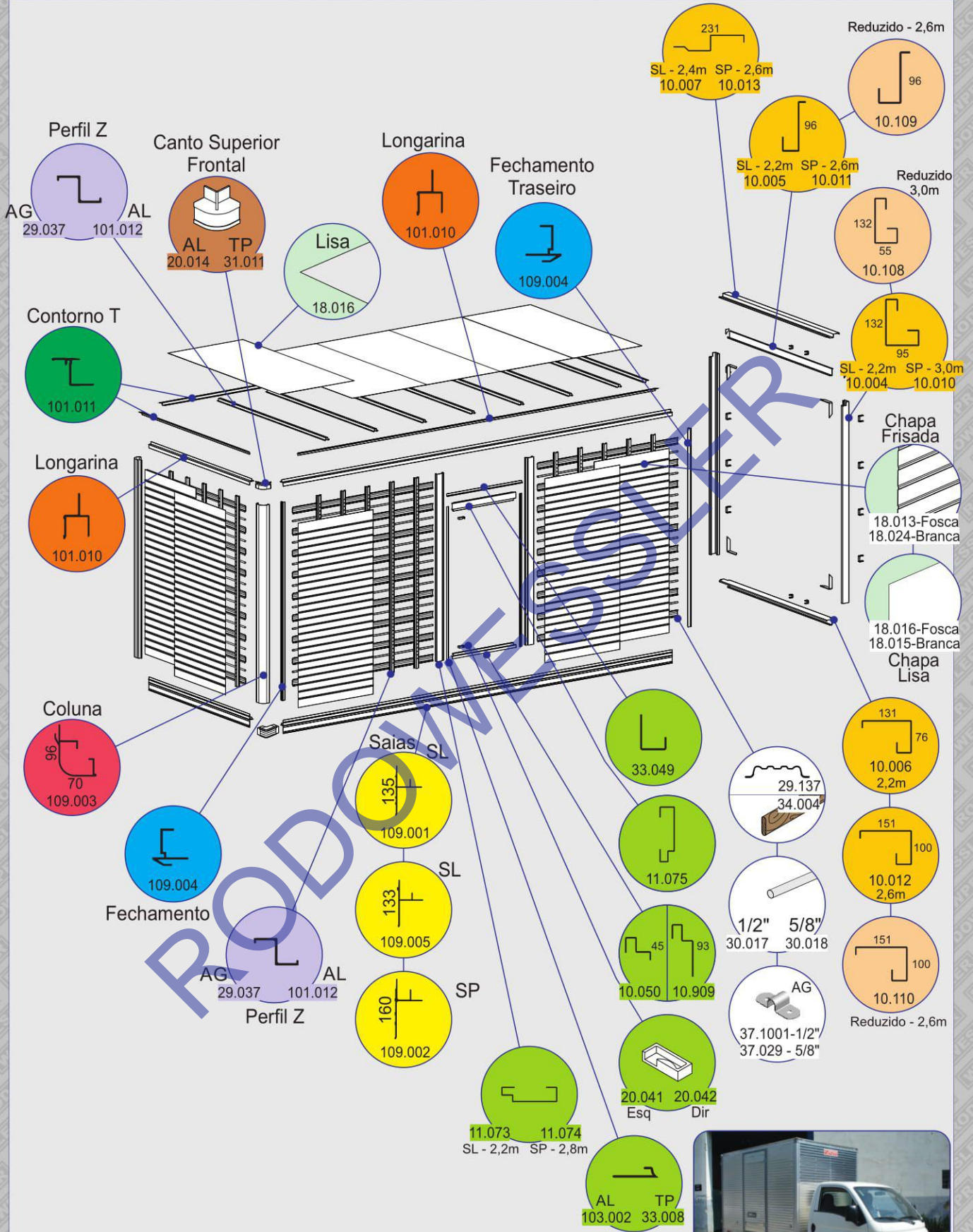

Figuras e Fotos Meramente Ilustrativas.

FURGÃO DURALUMÍNIO

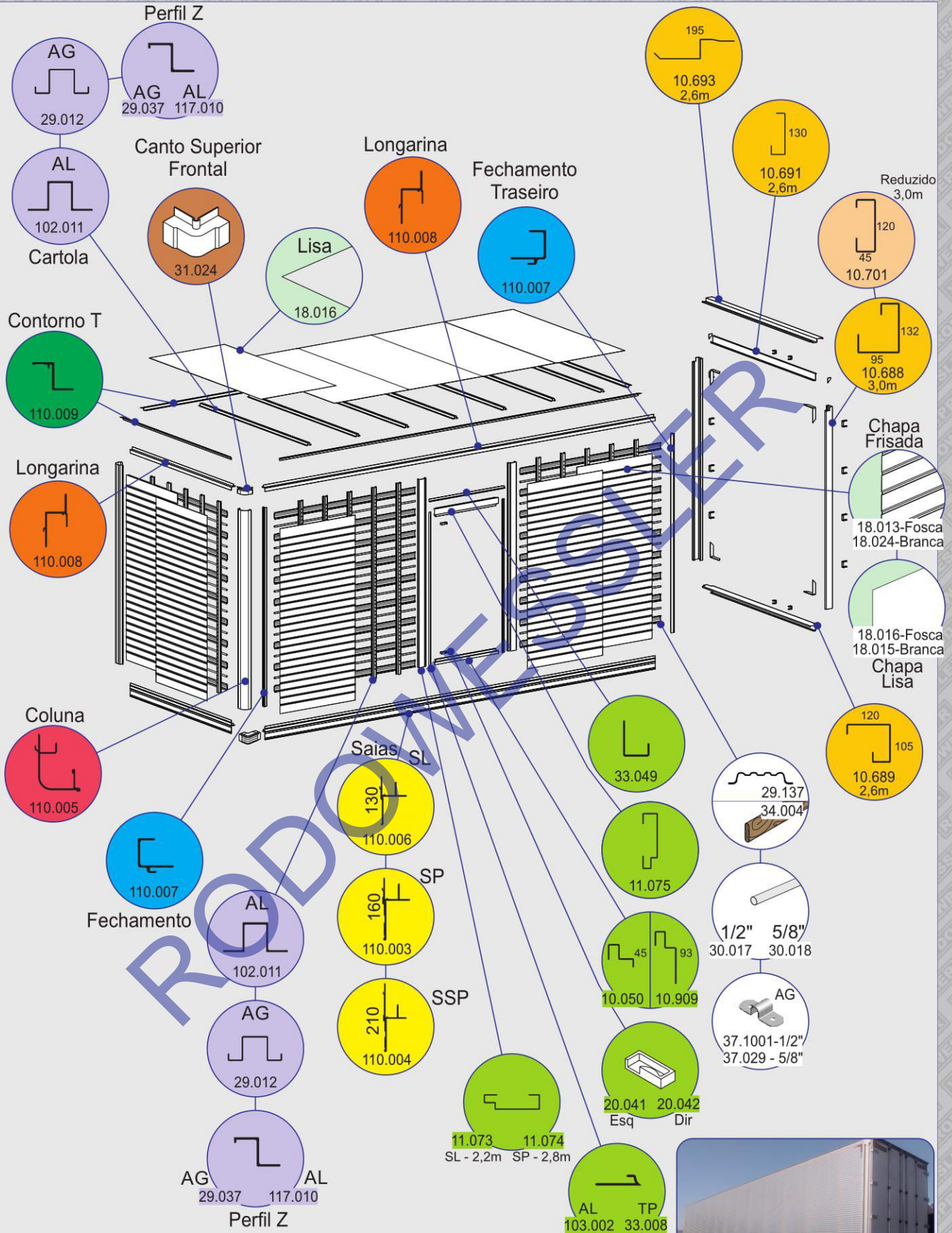

G U E R R A



Figuras e Fotos Meramente Ilustrativas.

FURGÃO DURALUMÍNIO

I D E R O L S E I

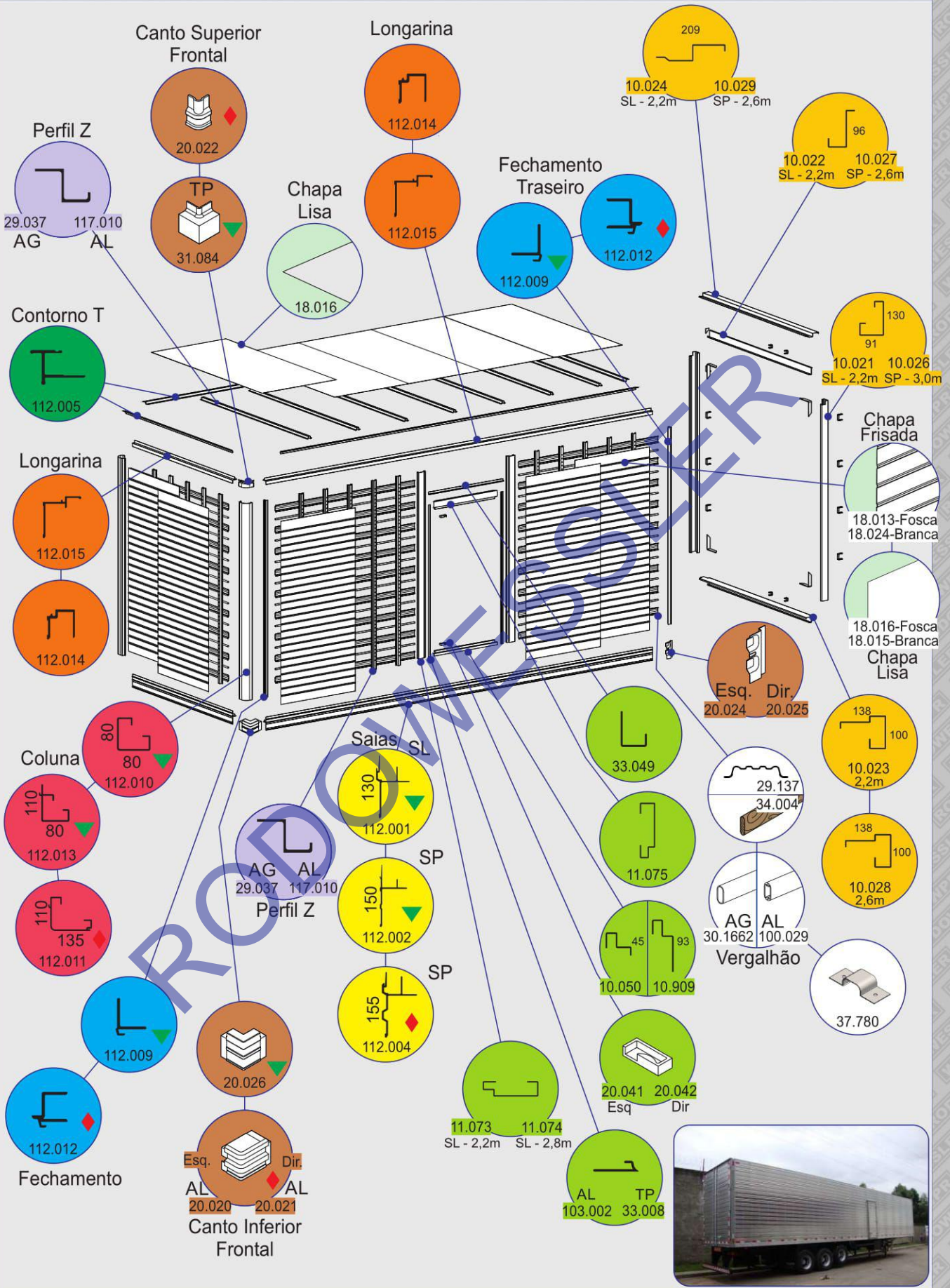

Figuras e Fotos Meramente Ilustrativas.



FURGÃO DURALUMÍNIO

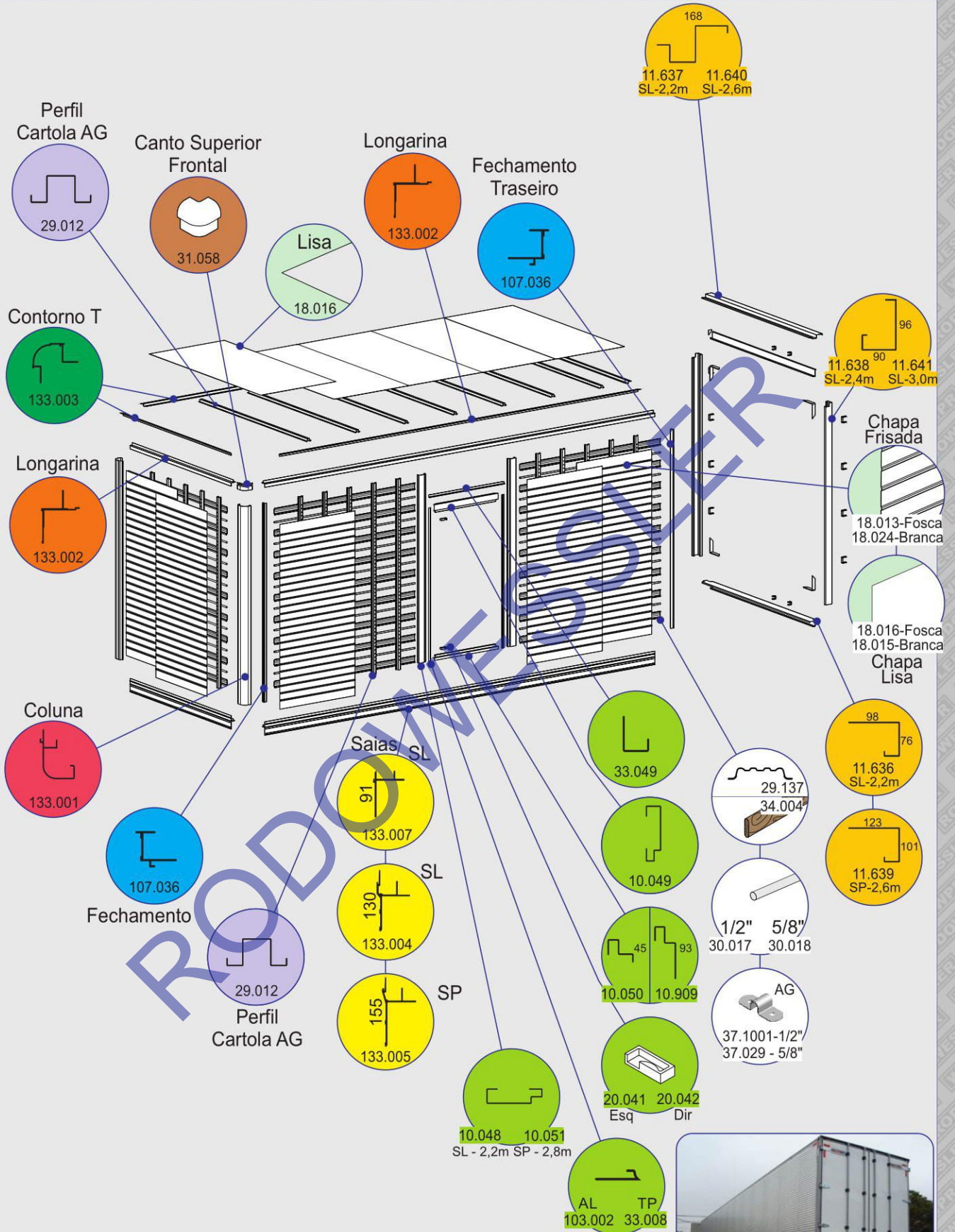

MAXFORT



Figuras e Fotos Meramente Ilustrativas.

FURGÃO DURALUMÍNIO

METALCAR QUALITAS TRUCK 4

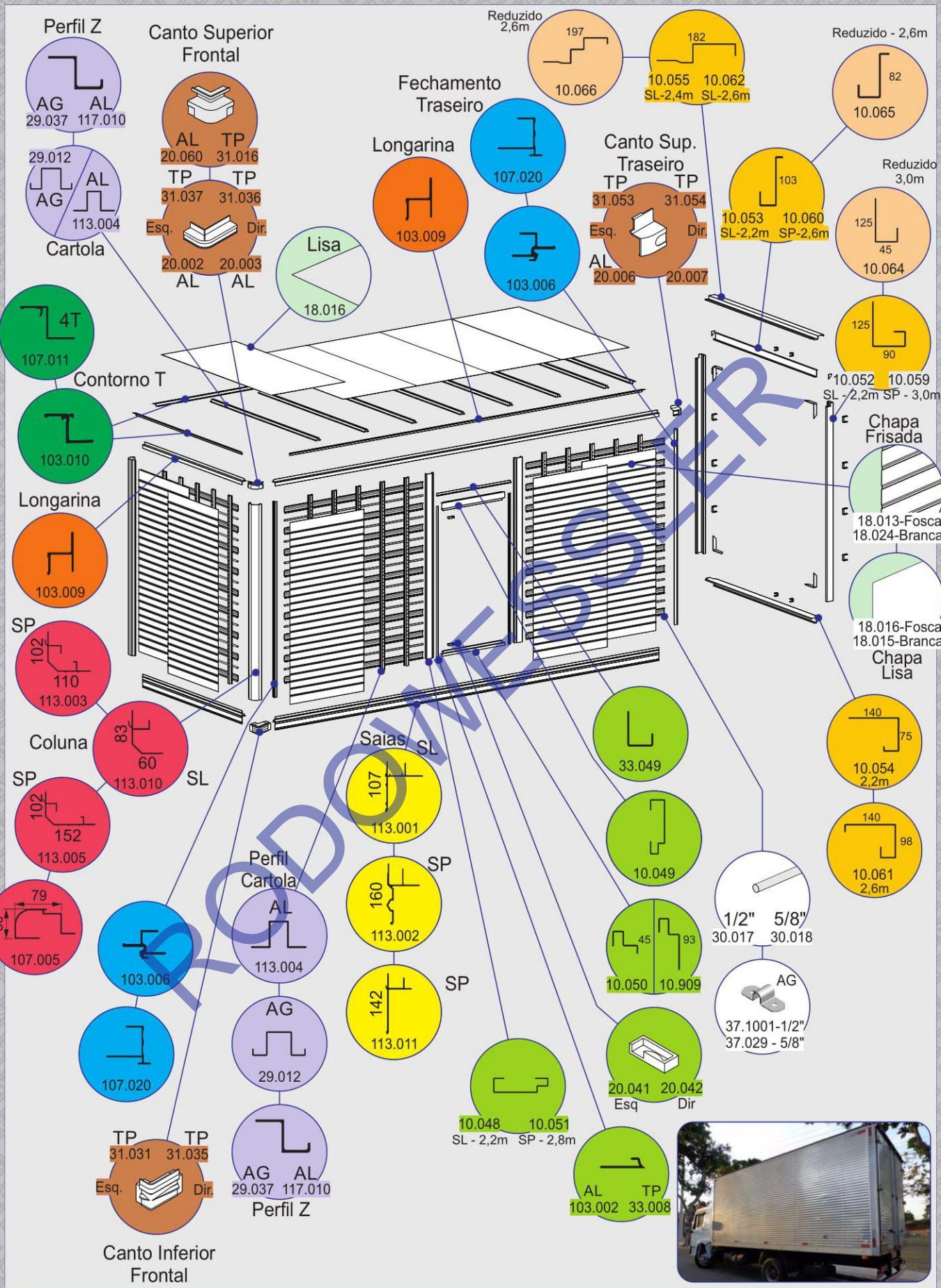

Figuras e Fotos Meramente Ilustrativas.

RODOWESSLER

Site: www.rodowessler.com.br
 e-mail: vendas@rodowessler.com.br

(11) 2431-5300

016



REFERÊNCIA EM PEÇAS PARA IMPLEMENTOS

FURGÃO DURALUMÍNIO

REALIZAÇÃO NOMINAL

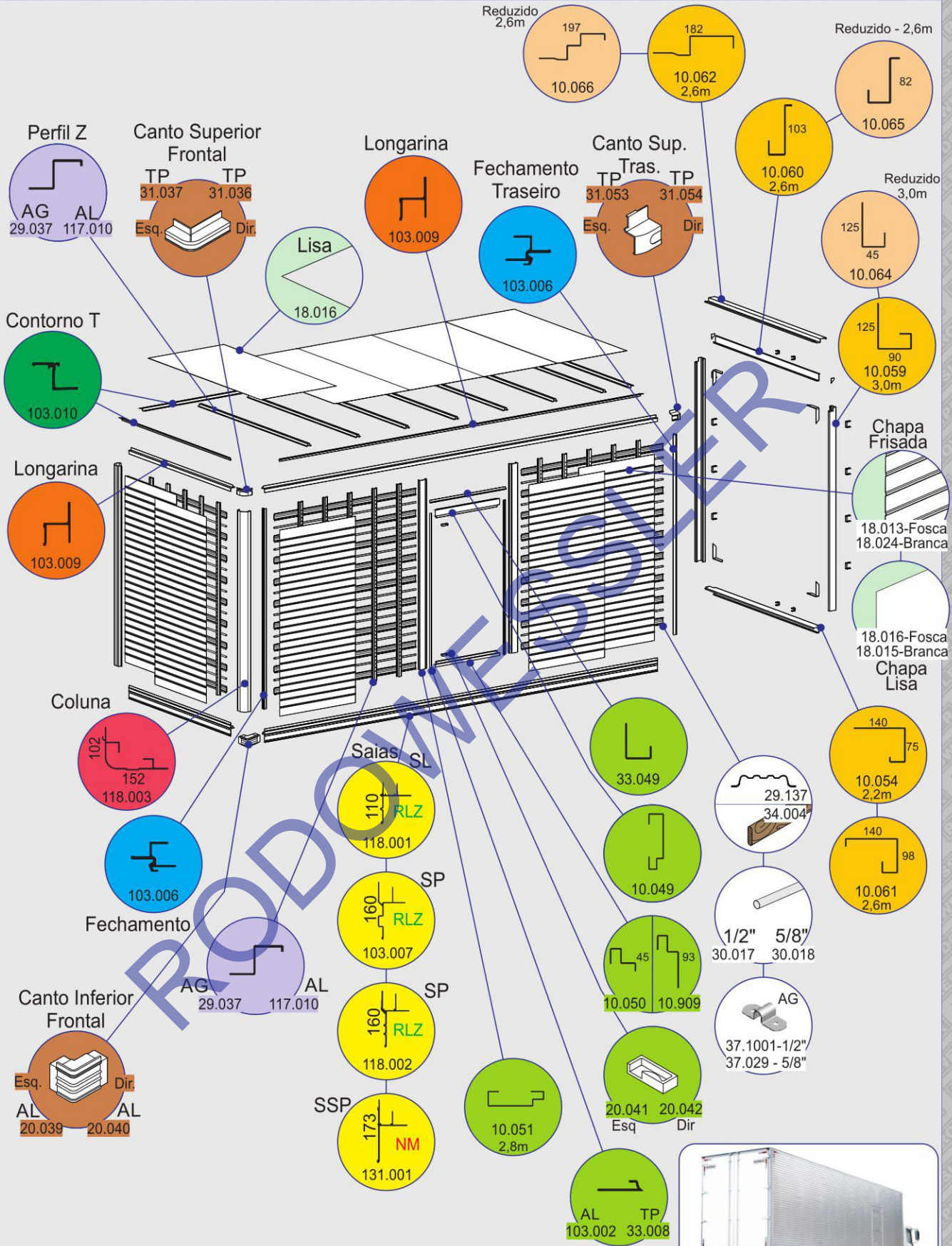

Figuras e Fotos Meramente Ilustrativas.

FURGÃO DURALUMÍNIO

RODOWESSLER O U R O

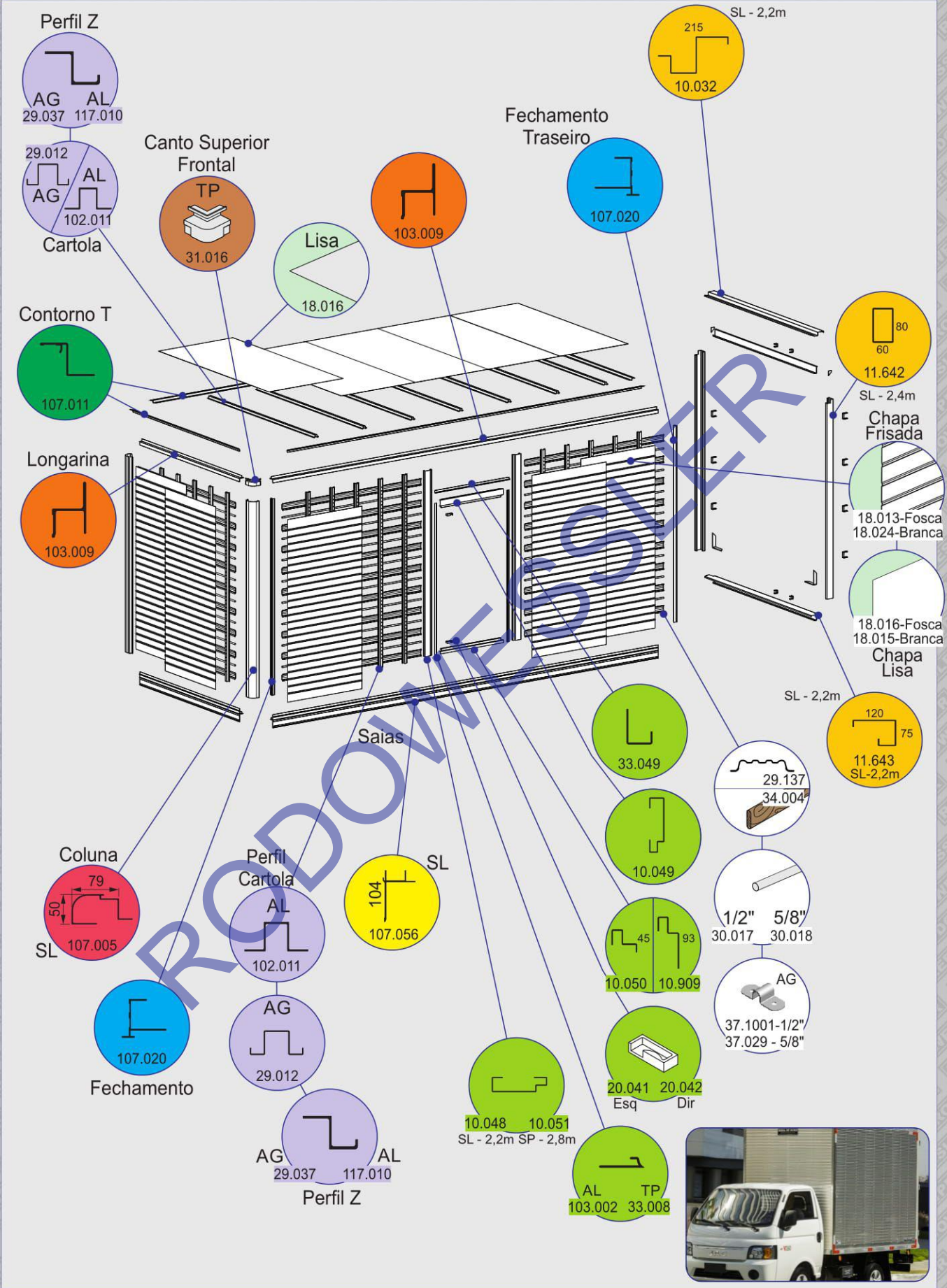

Figuras e Fotos Meramente Ilustrativas.

FURGÃO DURALUMÍNIO

S
A
O
P
E
D
R
O

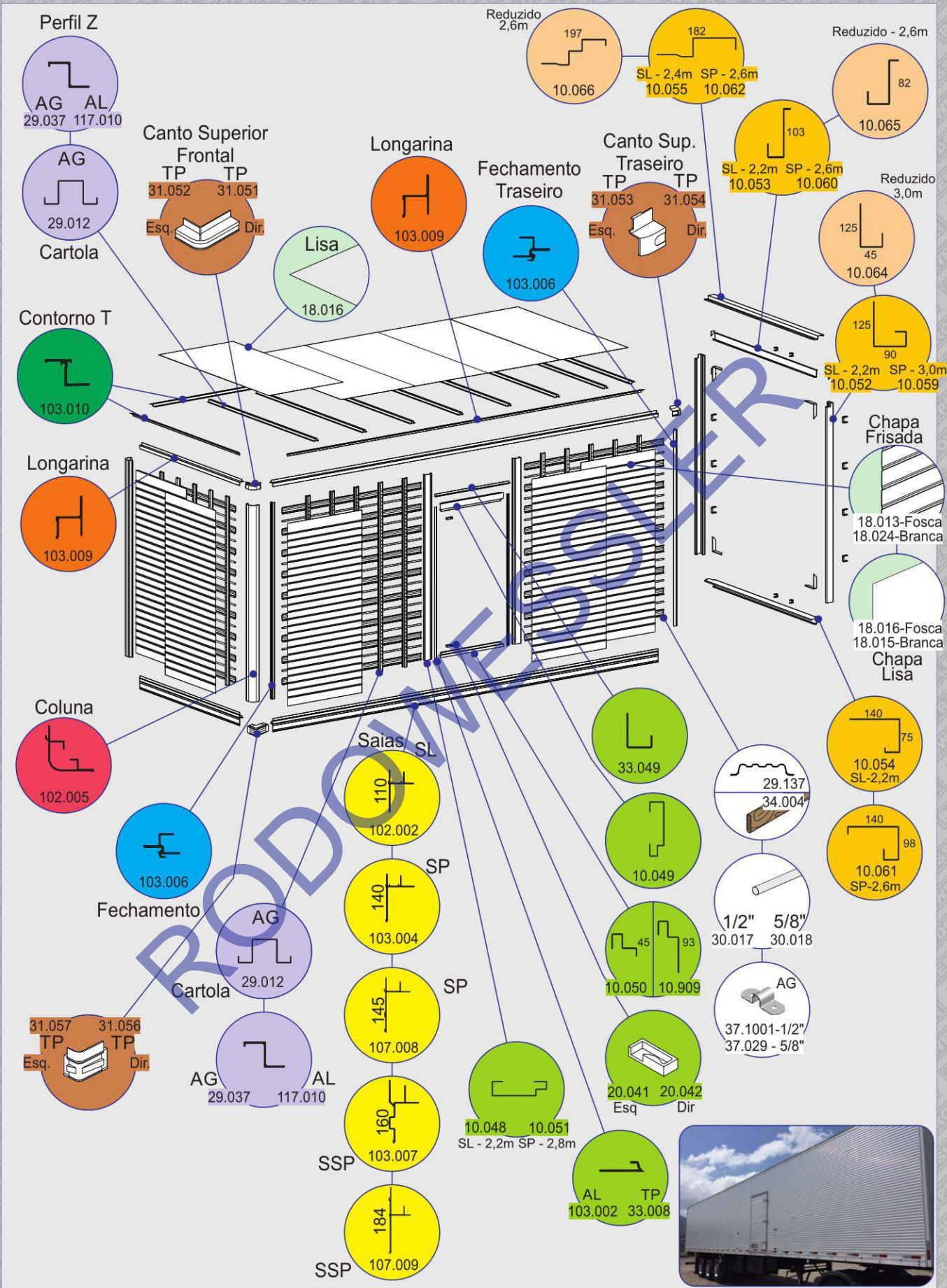

Figuras e Fotos Meramente Ilustrativas.

CAIXA DE CARGA - FURGÃO DURALUMÍNIO

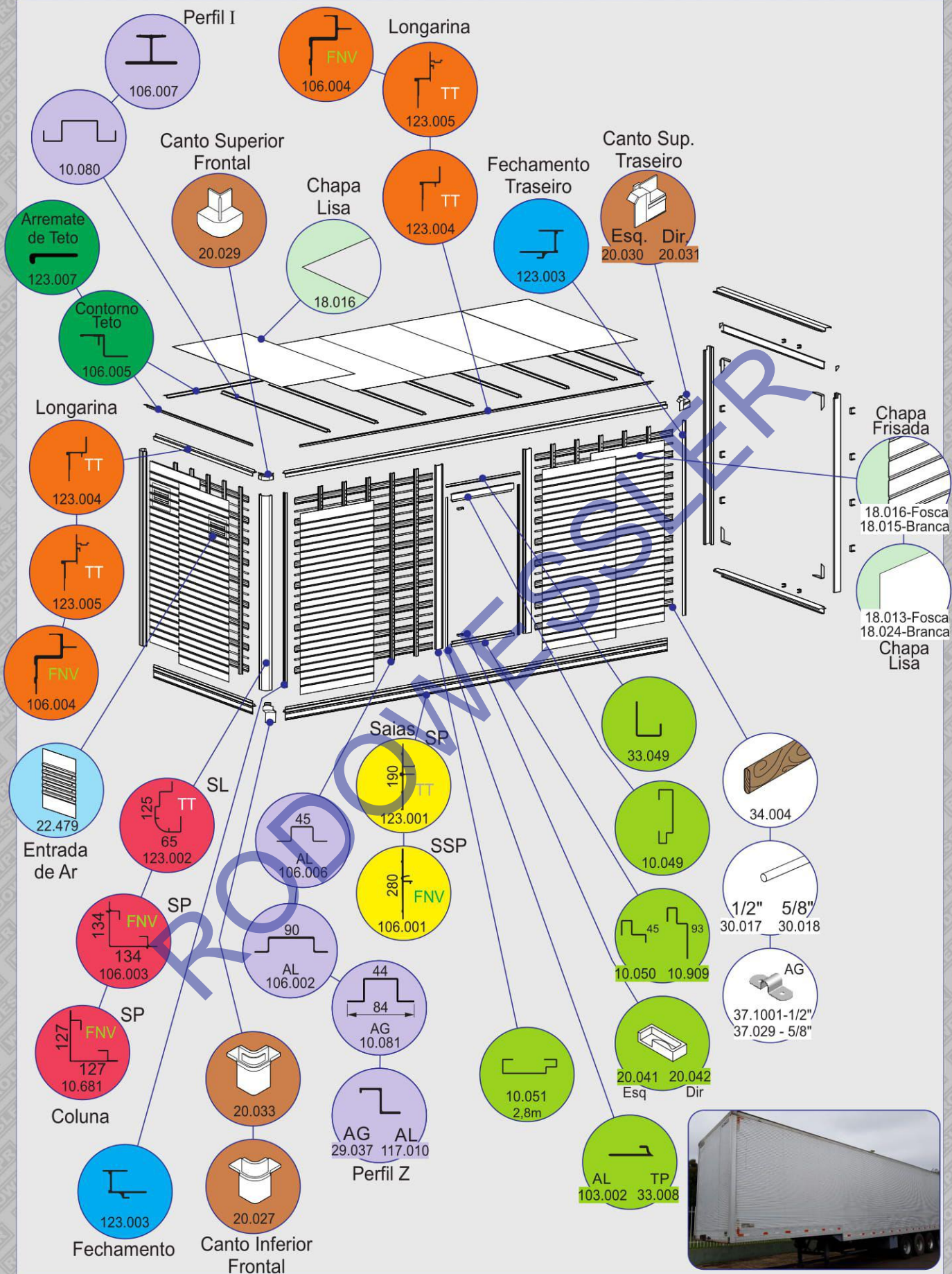

T
E
C
T
R
A
N
F
N
V

FURGÃO DURALUMÍNIO

TRUCK VAN

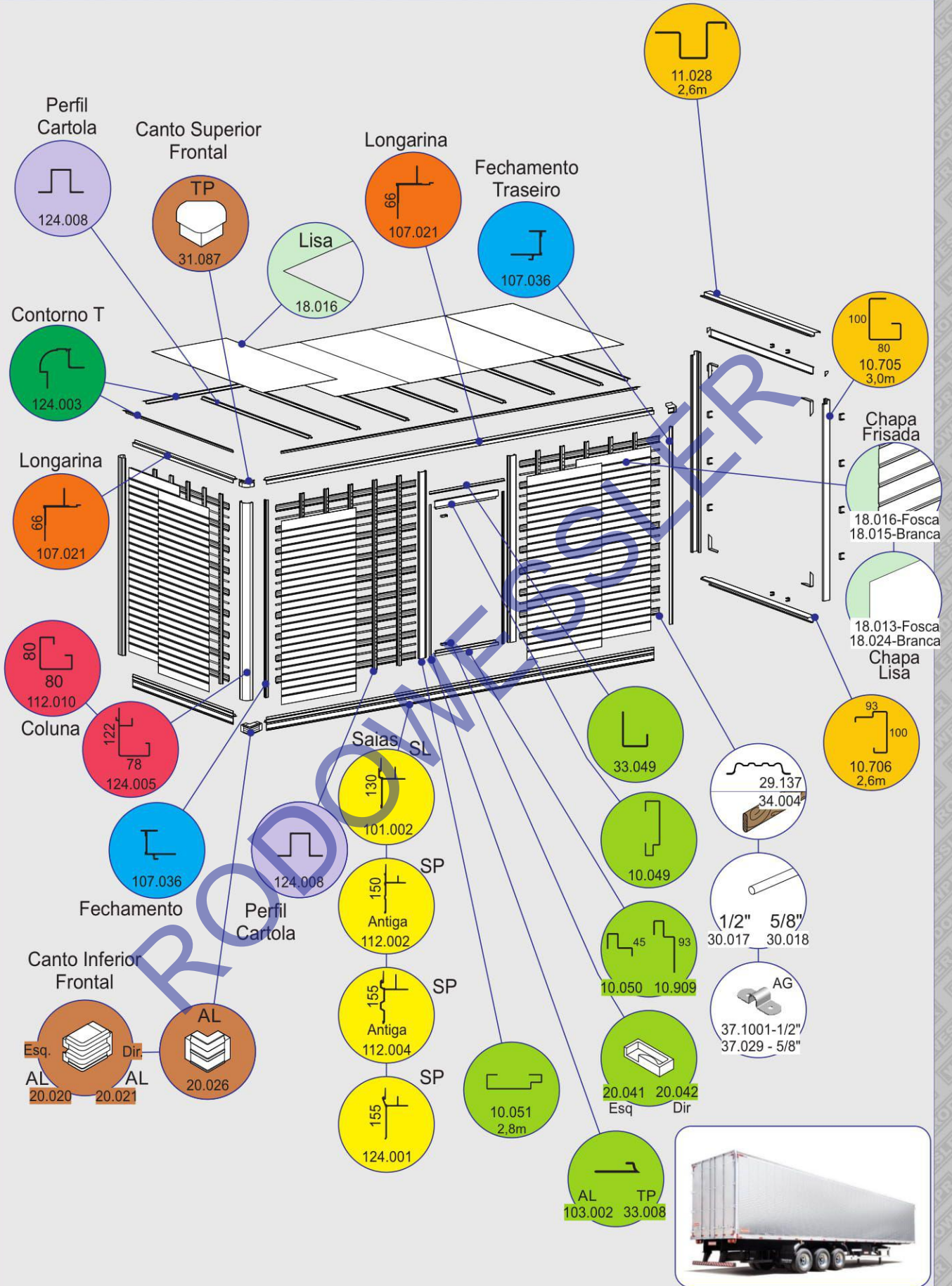

Figuras e Fotos Meramente Ilustrativas.

FURGÃO FRIGORÍFICO

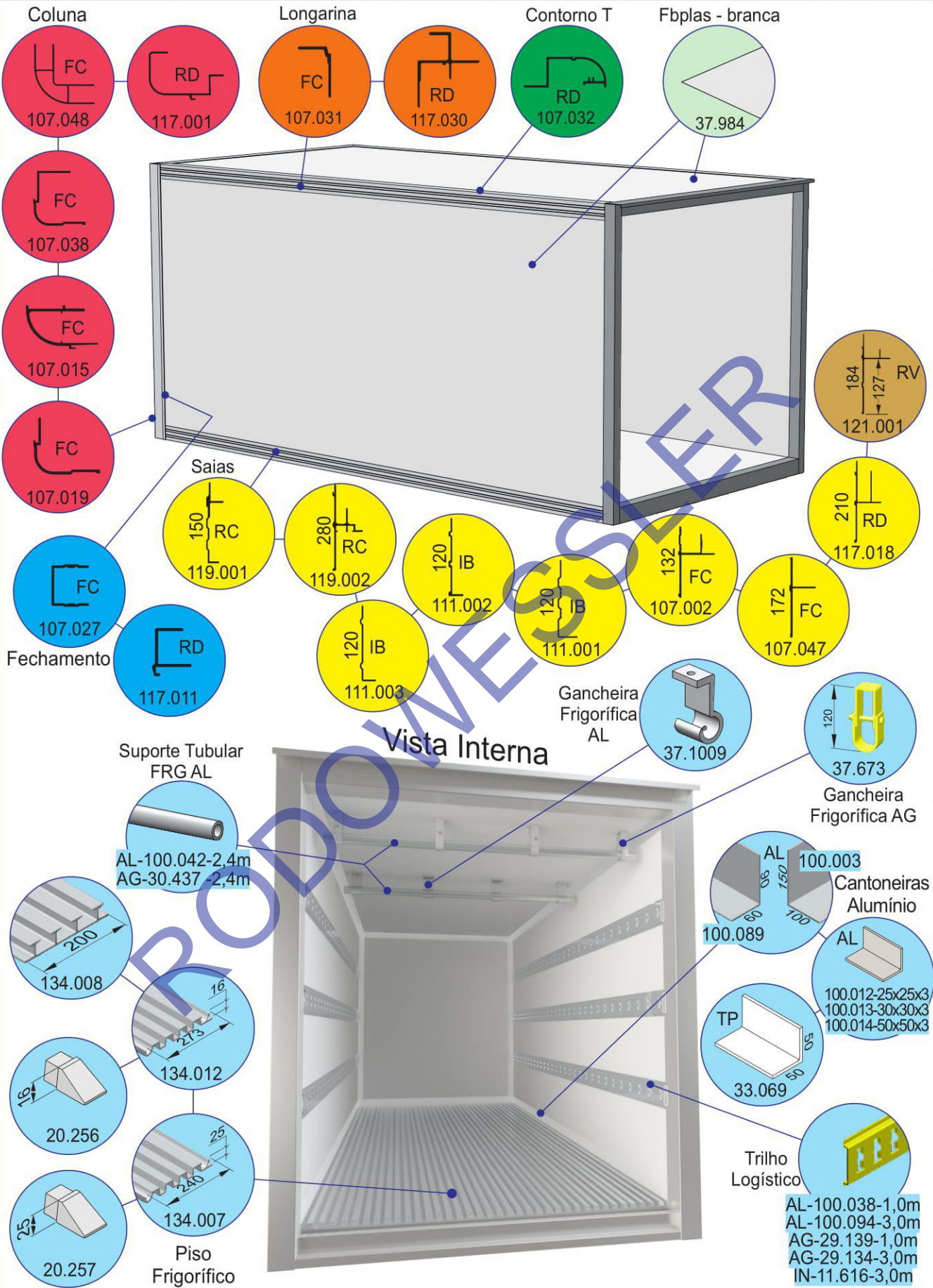

M
U
L
T
M
A
R
C
A
S

Figuras e Fotos Meramente Ilustrativas.

ACESSÓRIOS EXTERNOS

M
U
L
T
I
M
A
R
C
A
S

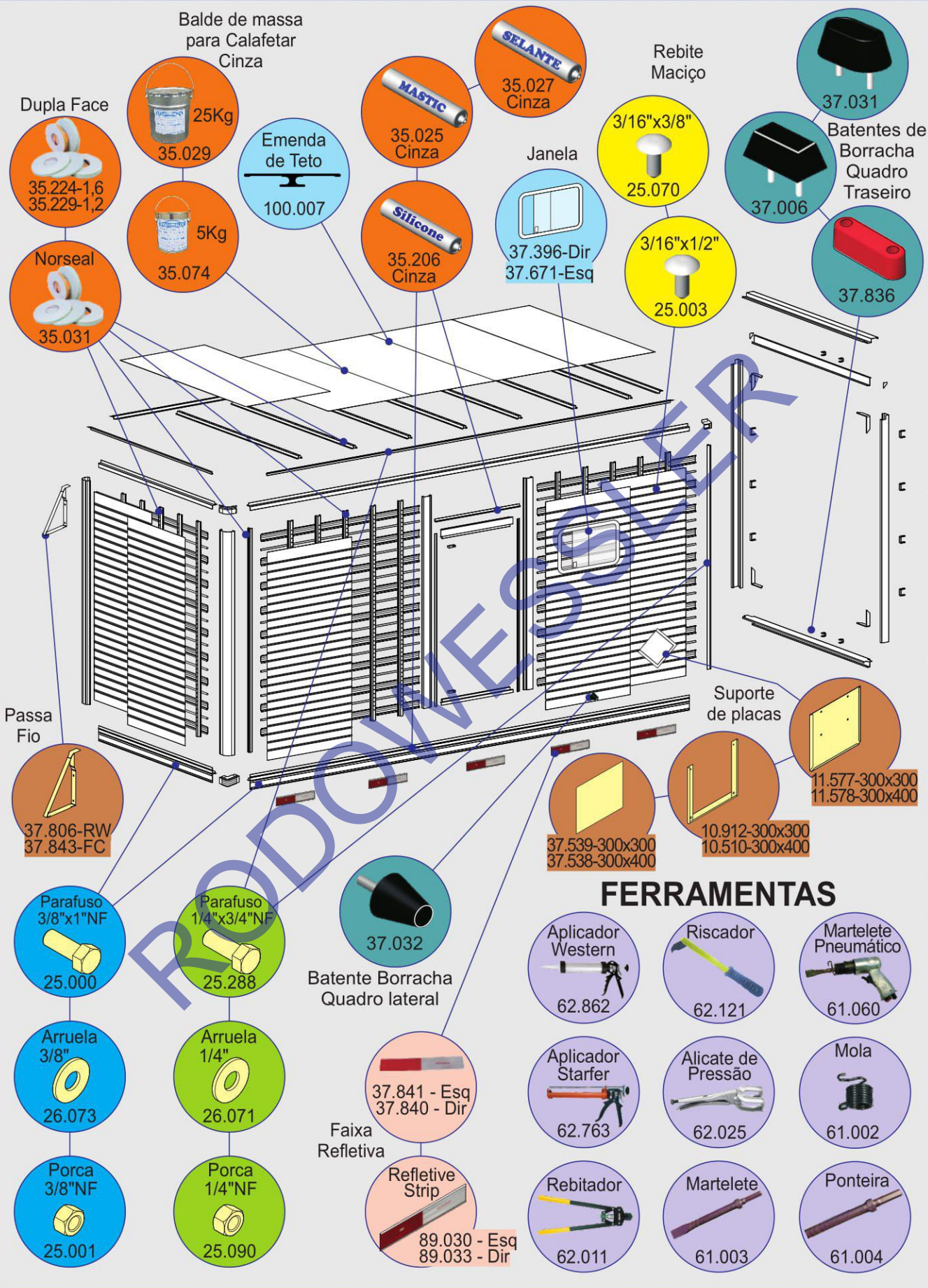

Figuras e Fotos Meramente Ilustrativas.



ACESSÓRIOS INTERNOS

MULTIMARCAS

Ripamentos

- AG SL 29.136
- AG SP 29.137
- AG RD 29.138
- TPI 33.045
- MAD 7cm - 34.006, 10cm - 34.004

Vergalhão

- AC 30.017 - 1/2", 30.018 - 5/8"
- AG AL 30.1662, 100.029
- AC 30.088-1/4"x1", 30.050-3/16"x1"

Rodapé

- 20x300 34.199
- 320 29.115
- 1/4" 25.108 - 1 1/4", 25.109 - 1 1/2", 25.111 - 2"
- 1/4" 26.128, 26.071

Chapa Lisa AC 1,2x3,0 m

Aço

- R15.002 - 2,65
- R15.005 - 1/8"
- R15.006 - 3/16"
- R15.003 - 1/4"

Chapa Xadrez AC - 1,2 x 3,0 m

Aço

- R15.045 - 1/8"
- R15.031 - 3/16"
- R15.057 - 1/4"

Chapa Xadrez AL - 1,0 x 2,5 m

Alumínio

- R14.103 - 1,20
- R14.104 - 1,50
- R14.105 - 2,20
- R14.106 - 2,70

Assoalho Naval

Madeira

- 34.021-16mm
- 34.022-18mm
- 34.024-20mm

Assoalho M/F-2,5m

Madeira

- 34.017-14mm
- 34.019-16mm
- 34.001-*10 cm
- 34.028-*15 cm

Perfil Junção

- 10.265 - 14mm
- 10.977 - 16mm
- 10.267 - 18mm
- 10.268 - 20mm

Perfil Fechamento

- 10.979 - 14mm
- 10.981 - 16mm
- 10.982 - 18mm
- 10.983 - 20mm
- 11.420 - 40mm

5x45 25.543

37.1001-1/2", 37.029 - 5/8"

31.062 - 1/2", 31.063 - 5/8"

37.780

4x13 26.805, 5,5x19 26.693

25.121 - 1", 25.123 - 1 1/2", 25.125 - 2", 25.127 - 2 1/2"

25.936, 26.072

1/4" x 1" 25.1066

AMARRAÇÃO DE CARGA

Trilho Logístico

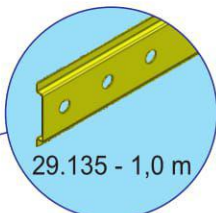
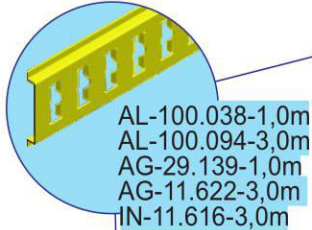

Trava Carga

Alumínio 37.808 - SL
Aço Galvan. 37.1056 - SL
37.1050 - SP

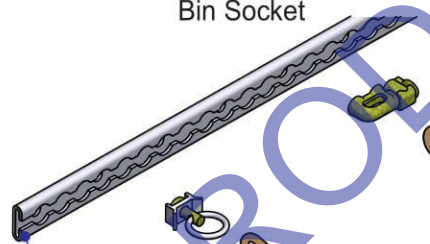
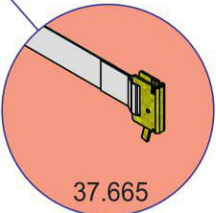
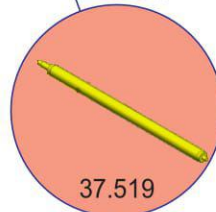
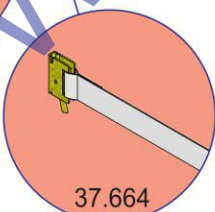
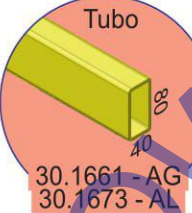
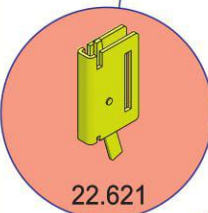

M
U
L
T
I
M
A
R
C
A
S

ENVELOPAMENTO DE TETO

Lona para teto de furgão

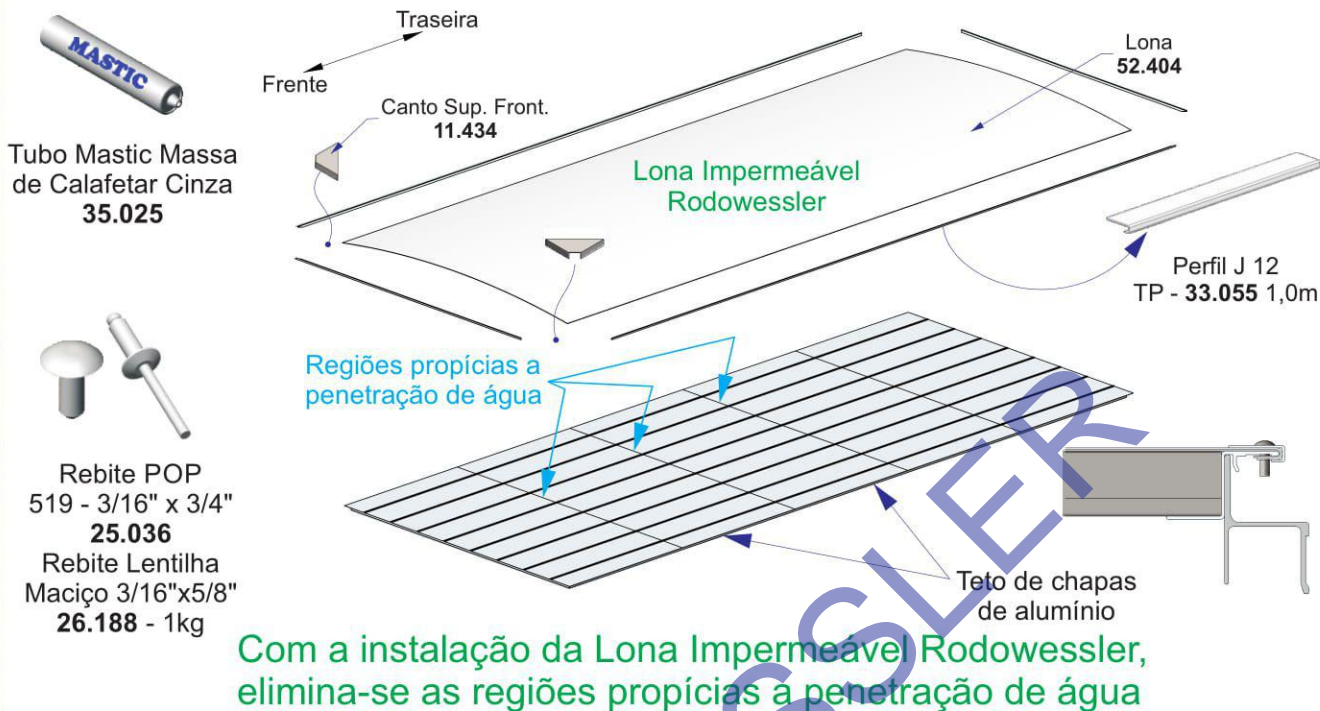

Chapas Inteiriças em Alumínio ou em Fbplas



Figuras e Fotos Meramente Ilustrativas.

RODOWESSLER

Peças para Implementos Rodoviários

Site: www.rodowessler.com.br
e-mail: vendas@rodowessler.com.br

(11) 2431-5300



SERVIÇOS DE FRISAGEM DE CHAPAS



Traga sua bobina de alumínio e utilize nosso serviço de industrialização. Sua chapa frisada com agilidade e confiabilidade. Consulte nosso depto. comercial.

BOBINAS DE ALUMÍNIO

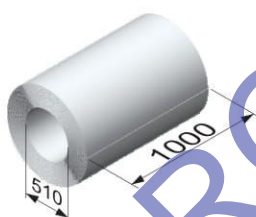

Bobina Fosca AL 1000
R17.003 - esp 0,7mm
R17.013 - esp 0,8mm

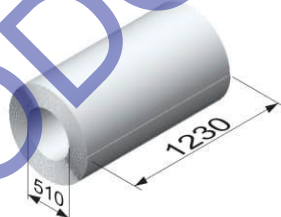

Bobina Fosca AL 1230
R17.005 - esp 0,7mm
R17.008 - esp 0,8mm



Bobina Fosca AL 1250
R17.006 - esp 0,7mm
R17.010 - esp 0,8mm

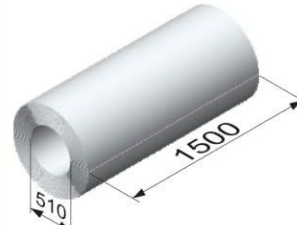

Bobina Fosca AL 1500
R17.004 - esp 0,7mm
R17.014 - esp 0,8mm

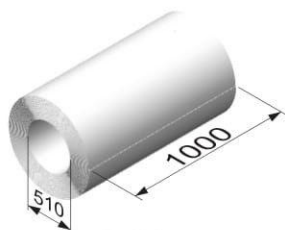

Bobina
Branca AL 1000
R17.011 - esp 0,8mm

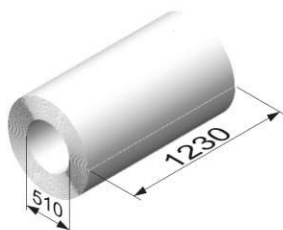

Bobina
Branca AL 1230
R17.012 - esp 0,8mm

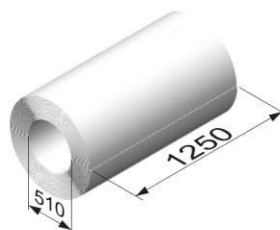

Bobina
Branca AL 1250
R17.001 - esp 0,8mm



Chapa Teto
AL -17.019 -Natural
Fb - 37.972 - Cinza
Fb -37.984- Branca

Figuras e Fotos Meramente Ilustrativas.

RODOWESSLER

Site: www.rodowessler.com.br
e-mail: vendas@rodowessler.com.br

(11) 2431-5300

028

Peças para Implementos Rodoviários



RODOWESSLER[®]

REFERÊNCIA EM PEÇAS PARA IMPLEMENTOS

FURGÃO LONADO



A Rodowessler tem a mais completa linha de peças para reposição de sider. Ganhe tempo comprando tudo na Rodowessler.



FURGÃO LONADO

F A C C H I N I

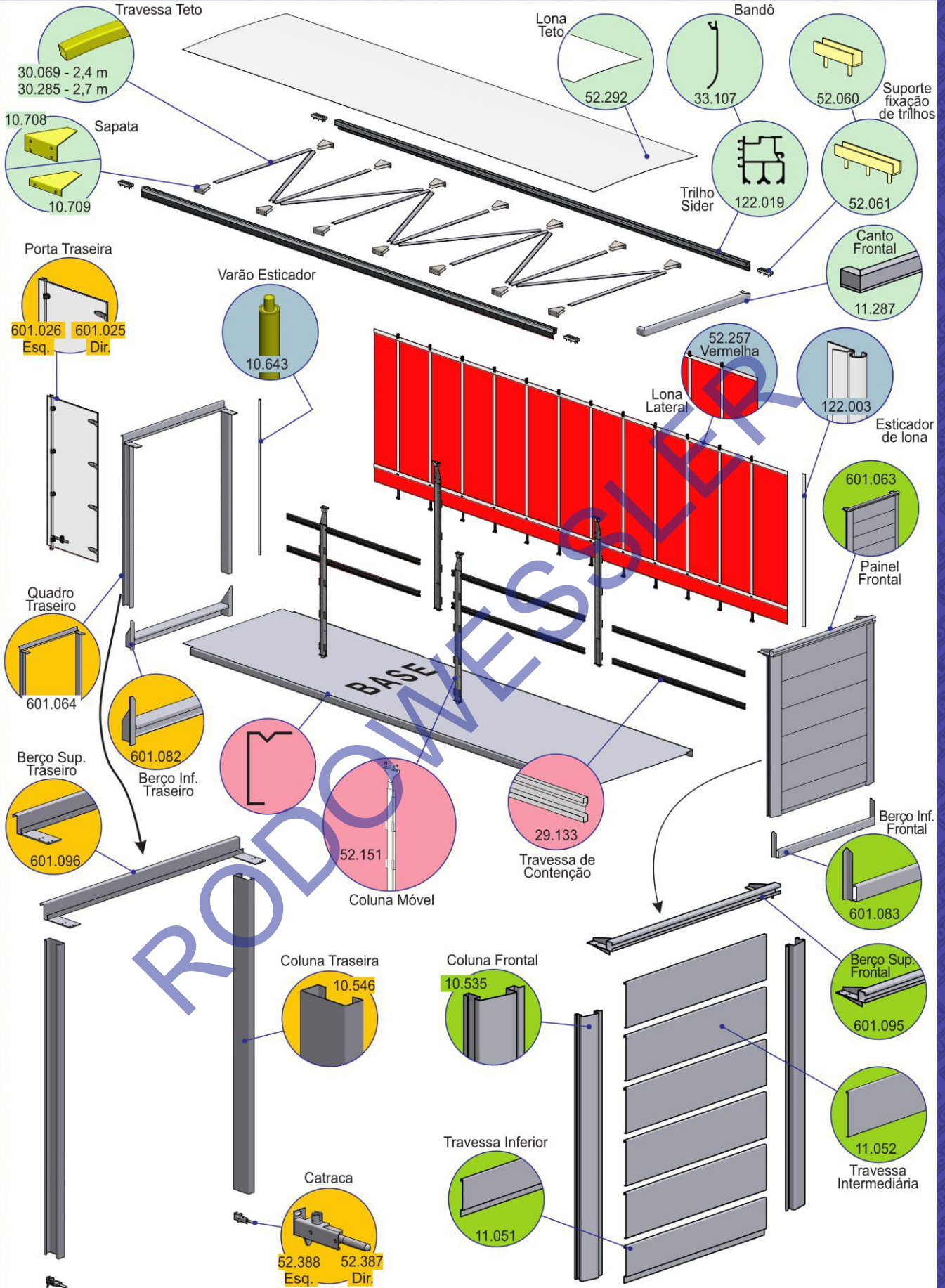

Figuras e Fotos Meramente Ilustrativas.



FURGÃO LONADO (Acima 2011)

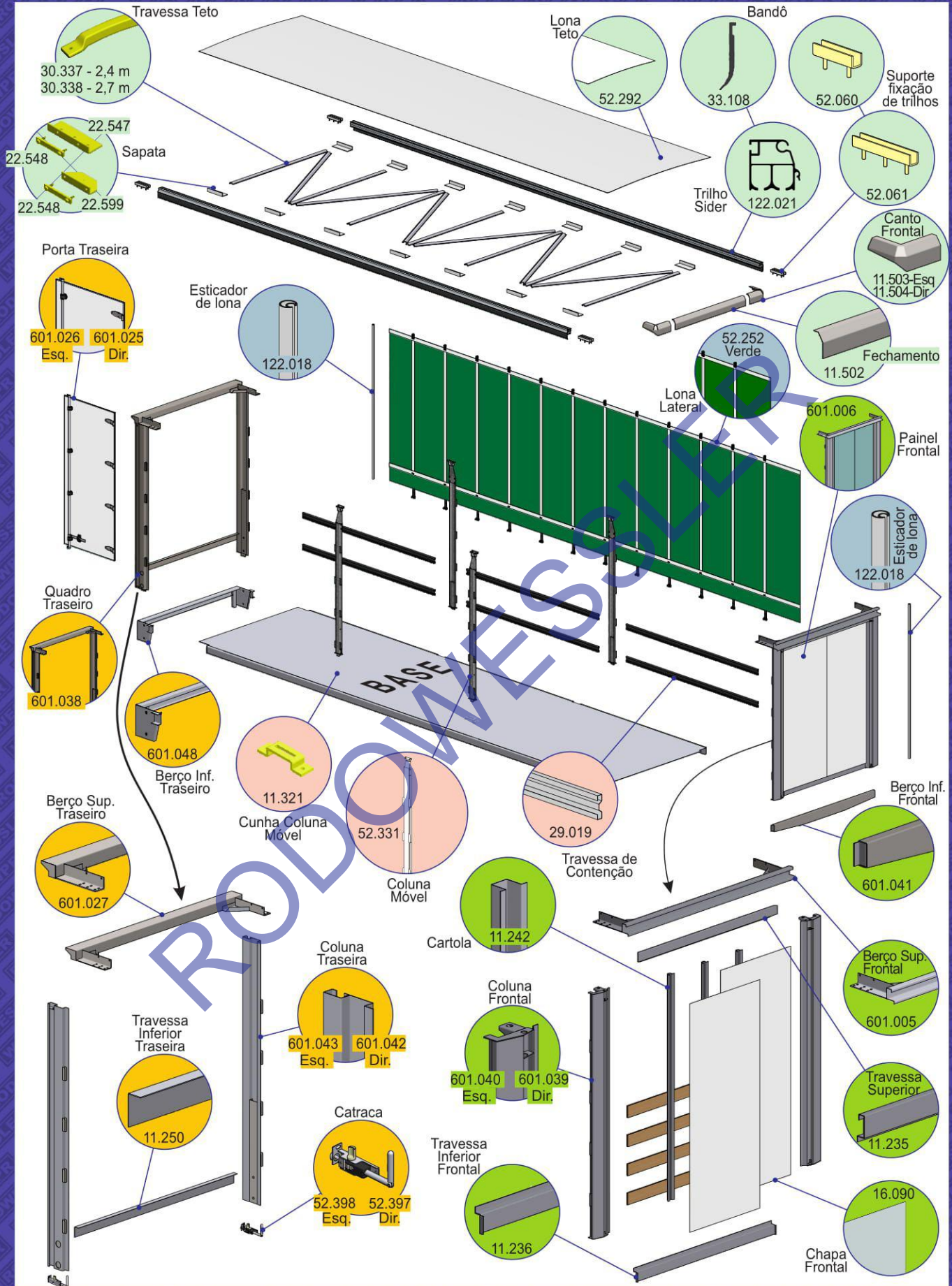

R
A
N
D
O
N

Figuras e Fotos Meramente Ilustrativas.

FURGÃO LONADO SL

RODOWESSLER

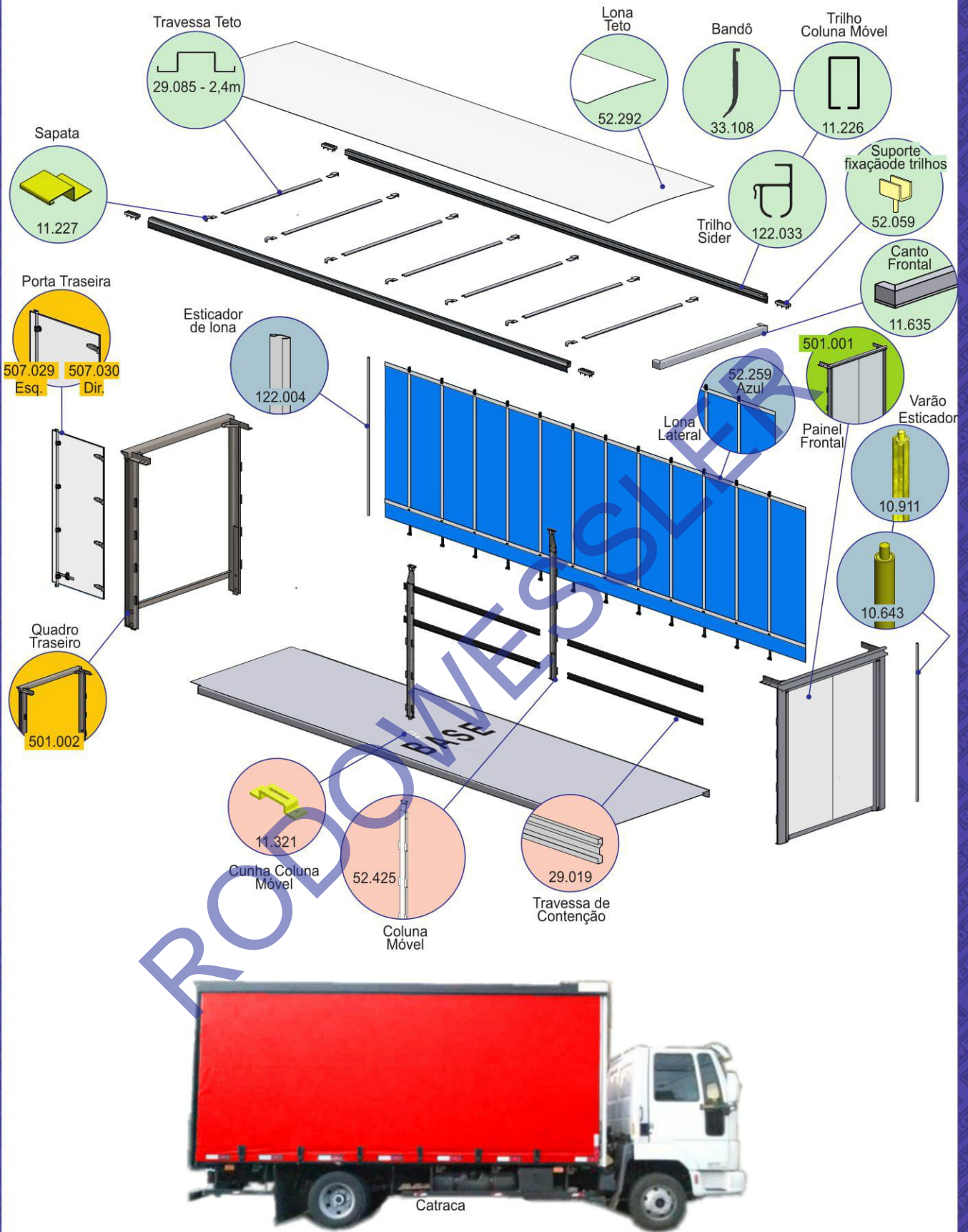

Figuras e Fotos Meramente Ilustrativas.

FURGÃO LONADO SP

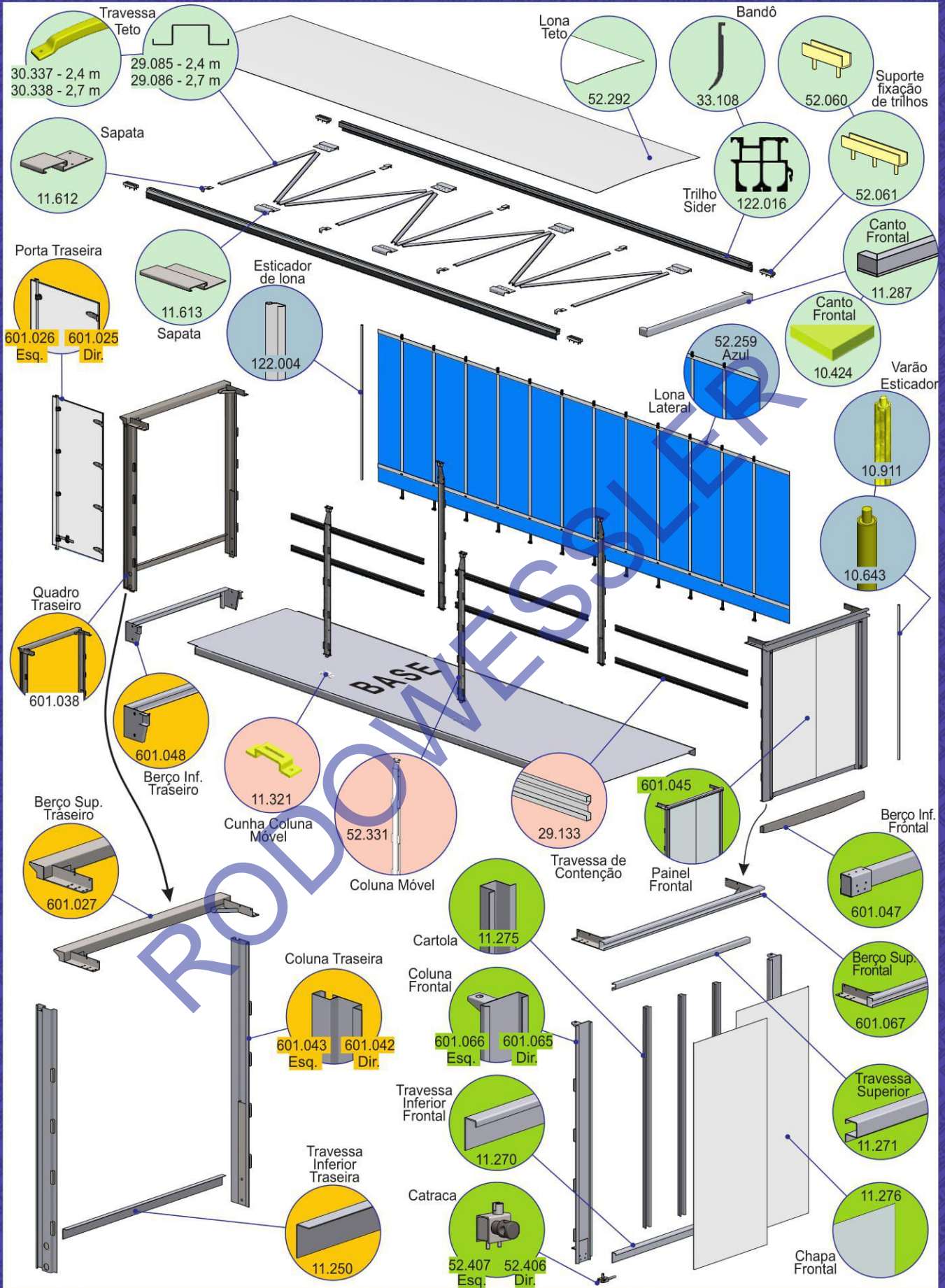

R
O
D
O
W
E
S
S
L
E
R

COLUNA MÓVEL

M
U
L
T
I
M
A
R
C
A
S

<p>Trilho Bando Piso Corrimão</p> <p>A altura do topo do corrimão até a base do trilho</p> <p>B altura do corrimão</p>	<p>52.262</p>	<p>52.413 52.262 52.328</p> <p>CJ Coluna Móvel Conv. Dobradiça 52.126</p>	<p>52.413 52.262 52.329</p> <p>CJ Coluna Móvel Conv. Cunha 52.346</p>
<p>Para trilho de ferro</p> <p>Pé de Pato Duplo 52.168</p>	<p>Corpo da Coluna Móvel Multimarcas 52.262</p>	<p>Pé de Pato Simples 52.413</p>	<p>Pé de Pato Simples 52.413</p>
<p>31.046</p> <p>Suporte da Roldana Pé de Pato Simples 52.079</p>	<p>52.069 52.044</p> <p>Rodízio Local Longo 52.003</p>	<p>Dobradiça</p> <p>Braço Inferior Conv. 52.328</p>	<p>Cunha</p> <p>Braço Inferior RD-RW 52.329</p>
<p>112 280</p> <p>Rodízio Suporte *AG-52.070-112mm **AG-52.085-280mm</p>	<p>* **</p> <p>Suporte de Fixação 52.080 - Simples 52.263 - Composto</p>	<p>Peças para fixação da coluna na base do equipamento</p> <div style="display: flex; justify-content: space-between;"> <div data-bbox="790 1649 1125 1968"> <p>Caixa da Col. Móvel Conv. 52.078</p> <p style="writing-mode: vertical-rl; transform: rotate(180deg);">Vendido separadamente</p> </div> <div data-bbox="1125 1649 1476 1968"> <p>* **</p> <p>Alojamento Cunha *11.621 **11.321</p> <p style="writing-mode: vertical-rl; transform: rotate(180deg);">Vendido separadamente</p> </div> </div>	

Figuras e Fotos Meramente Ilustrativas.



















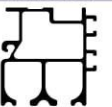

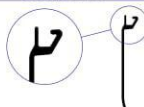



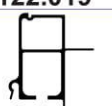

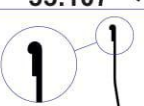

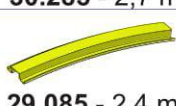

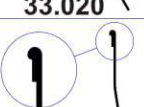



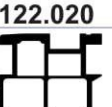

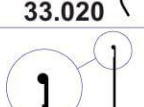

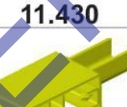

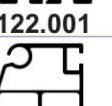

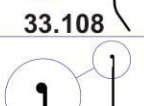





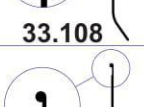

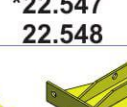







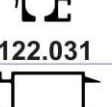

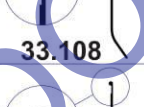







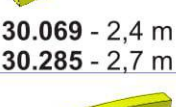

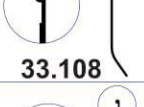



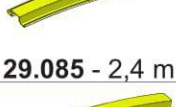

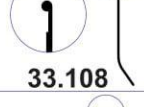
COLUNA MÓVEL

F
A
C
I
L
I
N
I
R
A
N
D
O
N

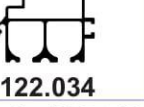
 <p>CJ Coluna Móvel FC Cunha 52.151</p>	 <p>CJ Coluna Móvel FC Dobradiça 52.345</p>	 <p>CJ Coluna Móvel RD Cunha 52.331</p>	 <p>CJ Coluna Móvel RD Dobradiça 52.347</p>
 <p>Pé de Pato FC 52.333</p>	 <p>Pé de Pato FC 52.333</p>	 <p>Pé de Pato RD-RW 52.330</p>	 <p>Pé de Pato RD-RW 52.330</p>
 <p>Braço Inferior FC 52.332</p>	 <p>Braço Inferior Conv. 52.328</p>	 <p>Braço Inferior RD-RW 52.329</p>	 <p>Braço Inferior Conv. 52.328</p>
<p>Peças para fixação da coluna na base do equipamento</p>			
 <p>Corrimão do equipamento</p>	 <p>Caixa da Col. Móvel Conv. 52.078</p>	 <p>Alojamento Cunha *11.621 **11.321</p>	 <p>Caixa da Col. Móvel Conv. 52.078</p>

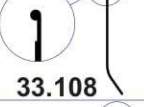
KIT TETO SIDER

M U L T I M A R C A S

	TRILHO	RODÍZIO	BANDÔ	EMENDA 1	EMENDA 2	SAPATA	TRAVESSA
Trilho CB	 122.009	 52.000	 33.020	 11.000	 11.021	 10.763	 29.085 - 2,4 m 29.086 - 2,7 m
Trilho FC	 122.019	 52.001	 33.107	 11.005		 10.708/10.709	 30.069 - 2,4 m 30.285 - 2,7 m
Trilho FC	 122.025	 52.000	 33.020	 11.008			 29.085 - 2,4 m 29.086 - 2,7 m
Trilho GR	 122.020	 52.001	 33.020		 11.055	 11.430	 30.487
Trilho RD	 122.001	 52.001	 33.108	 11.011	 11.010	 52.062	 30.069 - 2,4 m 30.285 - 2,7 m
Trilho RD	 122.021	 52.001	 33.108	 11.056	 *22.599 22.548	 *22.547 22.548	 30.337 - 2,4 m 30.338 - 2,7 m
Trilho RD	 122.023	 52.001	 33.108	 11.017	 11.012	 22.548 11.429	 30.069 - 2,4 m 30.285 - 2,7 m
Trilho RD	 122.031	 52.001	 33.108	 11.017		 22.548 11.429	 30.069 - 2,4 m 30.285 - 2,7 m
Trilho RF	 122.022	 52.001	 33.108	 11.057		 52.371	 30.069 - 2,4 m 30.285 - 2,7 m
Trilho RW	 122.033	 52.001	 33.108		 11.226	 11.227	 29.085 - 2,4 m
Trilho RW	 122.016	 52.001	 33.108	 11.011	 11.010	 11.612 - S 11.613 - T	 29.085 - 2,4 m 29.086 - 2,7 m
Trilho FIX	 122.034	 52.001	 33.108	 11.634	 *22.827 25.000	 *22.828 25.000	 30.337 - 2,4 m 30.338 - 2,7 m
Adaptação Trilhos	 52.001	 52.001	 33.108	 11.620		 11.612 - S 11.613 - T	 29.085 - 2,4 m 29.086 - 2,7 m

Figuras e Fotos Meramente Ilustrativas.

RODOWESSLER

Site: www.rodowessler.com.br
e-mail: vendas@rodowessler.com.br

(11) 2431-5300

038

Peças para Implementos Rodoviários



SISTEMA CENTRAL LOCK E ACESSÓRIOS

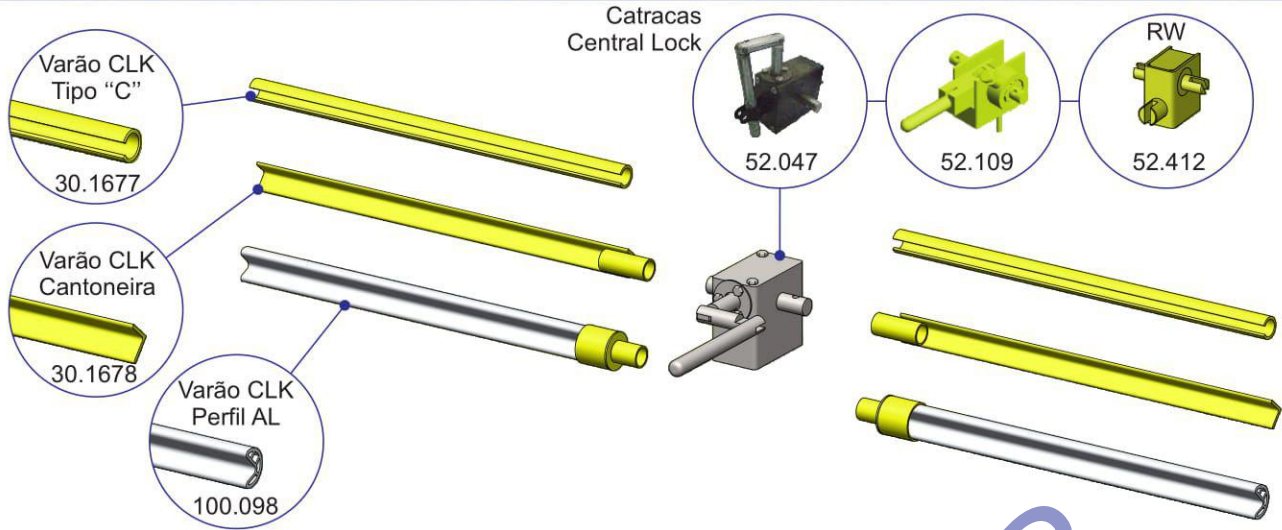

VARÃO ESTICADOR DE LONAS E CATRACAS

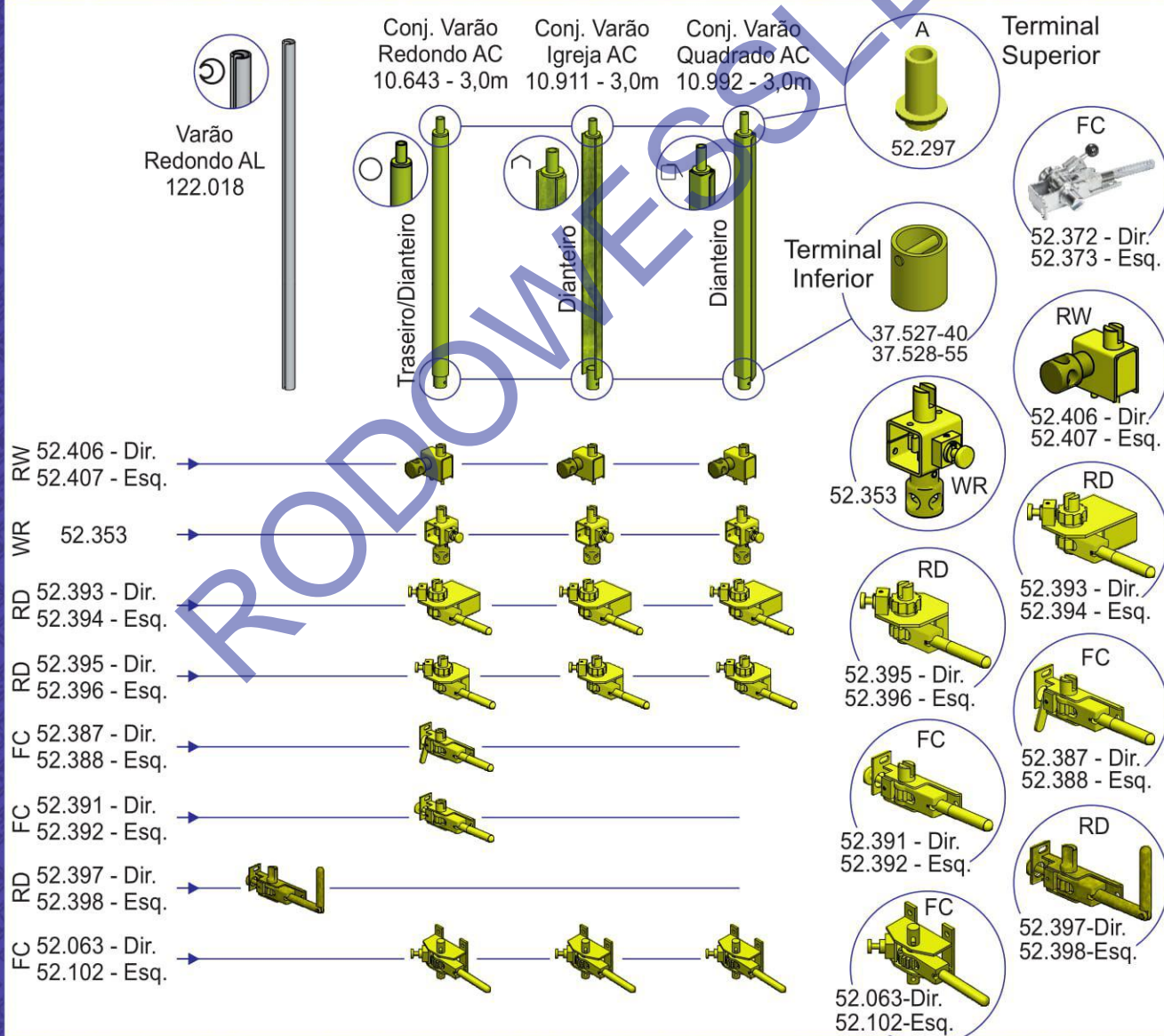

Figuras e Fotos Meramente Ilustrativas.

CJ DE LONA E ACESSÓRIOS COMPLEMENTARES

M U L T I M A R C A S

Cola Vinil
75 g
35.150

Perfil Emenda de lona
100.032

Cordão 11mm
33.018

CJ Lona SD
52.255 - Amarela
52.259 - Azul
52.258 - Branca
52.256 - Cinza
52.252 - Verde
52.257 - Vermelha
52.253 - Prata
52.251 - Preta

Rodízio SD
52.001

Perfil Esticador FC
122.003

RD
122.018

RD
122.004

Fivela
52.383 - TP AG
52.197 - TP TP

Fivela
52.040 Inox

Fivela
52.071 AG

Rabichos
52.415 *700mm
52.031 *1000mm

CJ DE LONA E ACESSÓRIOS COMPLEMENTARES

Cola Vinil
75 g
35.150

Perfil Emenda de lona
100.032

Cordão 11mm
33.018

CJ Lona SD
52.255 - Amarela
52.259 - Azul
52.258 - Branca
52.256 - Cinza
52.252 - Verde
52.257 - Vermelha
52.253 - Prata
52.251 - Preta

Rodízio SD
52.001

Perfil Esticador FC
122.003

RD
122.018

RD
122.004

Rabichos
52.249-*320mm
52.176-*340mm
52.194-*360mm

Rabichos
52.074-*380mm
52.133-*400mm
52.055-*420mm

Rabichos
52.266-*320mm
52.237-*340mm
52.205-*360mm

Rabichos
52.210-*380mm
52.193-*400mm
52.211-*420mm

Este tipo de rabicho é usado em equipamentos com sistema Central-Lock

Figuras e Fotos Meramente Ilustrativas.



LONAS DE SIDER

A Rodowessler vende desde o tecido da lona cortada até a bobina inteira e em quaisquer cores do padrão de mercado.

Cor da Lona	Código	
	Tecido	Bobina
 Amarelo	52.244	52.416
 Azul	52.405	52.417
 Branca	52.399	52.418
 Cinza	52.243	52.419
 Verde	52.248	52.420
 Vermelha	52.264	52.421
 Prata	52.246	52.422
 Preta	52.247	52.423

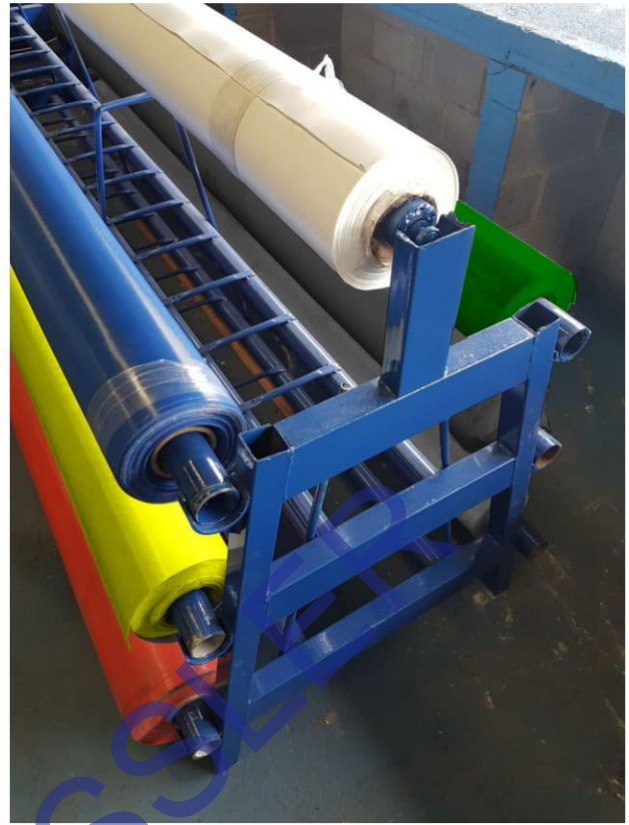

IMPRESSÃO MONOCOR E 4 CORES EM LONAS

Pintura Monocor



Impressão 4 Cores



Figuras e Fotos Meramente Ilustrativas.

RODOWESSLER

Peças para Implementos Rodoviários

Site: www.rodowessler.com.br
e-mail: vendas@rodowessler.com.br

(11) 2431-5300



M
U
L
T
I
M
A
R
C
A
S

Kit Sider Asa-Delta

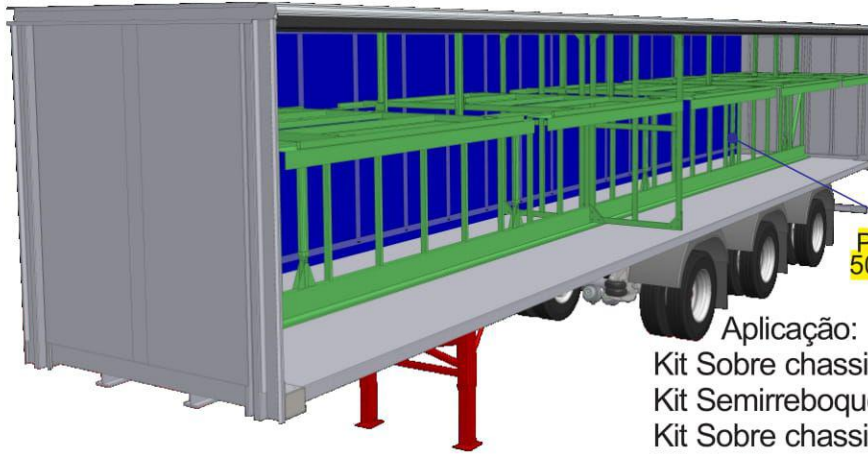

- Acionamento pneumático
- Travamento por cintas
- modelos de 8 a 28 paletes

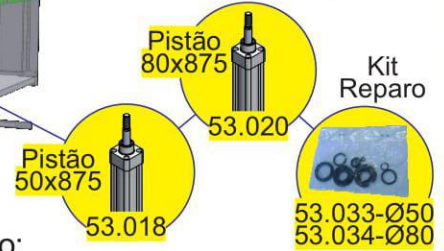

Aplicação:

- Kit Sobre chassis convencional - **600.029**
- Kit Semirreboque convencional - **600.014**
- Kit Sobre chassis auto serviço - **600.030**
- Kit Semirreboque auto serviço - **600.031**

Kit Top Sider Parcial

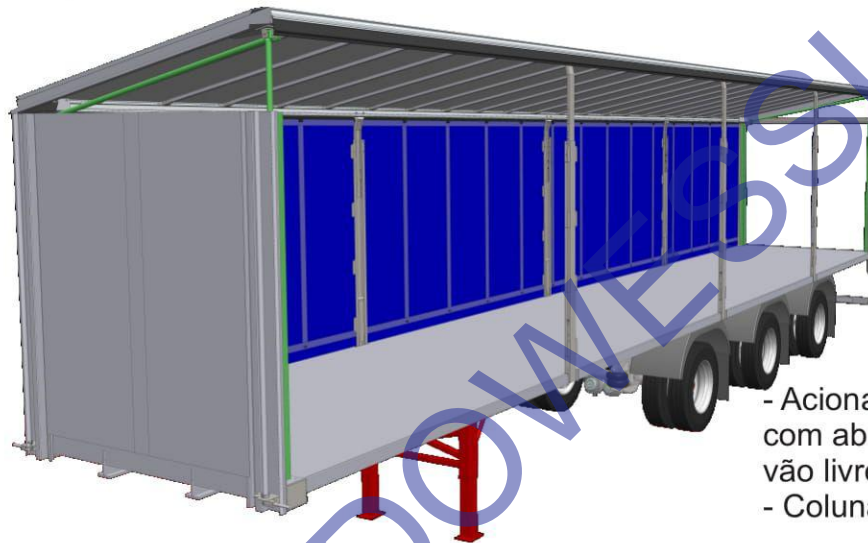

500 a 800 mm

Aplicação:

- Kit Sobre chassis - **600.025**
- Kit Semirreboque - **600.026**

- Acionamento lateral pneumático com abertura de 500 a 800 mm no vão livre
- Coluna Móvel Telescópica

Kit Top Sider Total

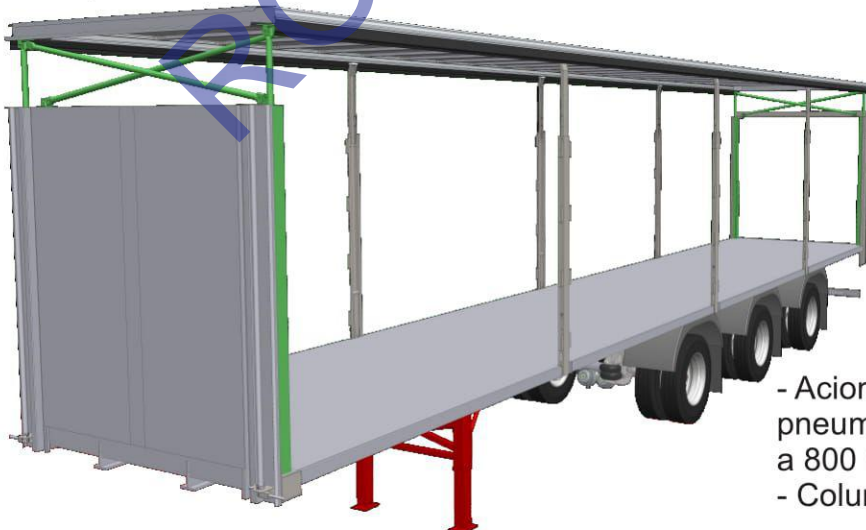

500 a 800 mm

Aplicação:

- Kit Sobre chassis - **600.027**
- Kit Semirreboque - **600.028**

- Acionamento dianteiro e traseiro pneumático com abertura de 500 a 800 mm no vão livre
- Coluna Móvel Telescópica

RODOWESSLER[®]

REFERÊNCIA EM PEÇAS PARA IMPLEMENTOS

EQUIPAMENTOS LOGÍSTICOS

Trasporte de
vestuários



Porta roll up



Double deck



Piso roletado

Na Rodowessler você encontra uma grande variedade de produtos destinados à otimização de seu implemento.

Ligue para (11)2431-5300
e **Aumente a Produtividade**
de sua logística.

TRANSPORTE DE VESTUÁRIO



VARÃO CABIDEIRO
37.299



Trava Tensionadora
** 37.842
* 37.801

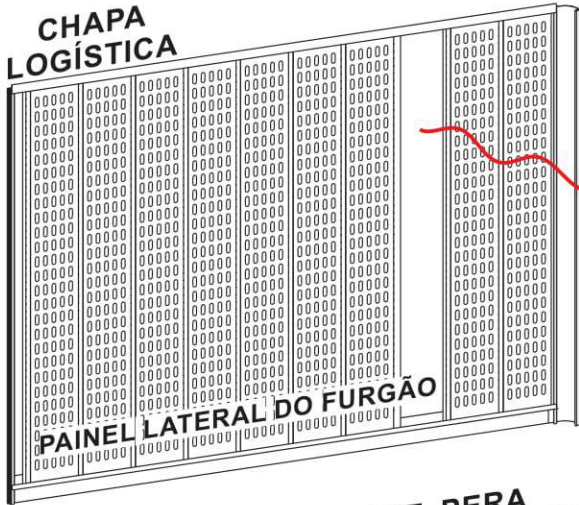

Chapa Logística
11.298 - 1,0 m
11.078 - 2,7 m
11.293 - 3,0 m



Chapa Logística
11.648 - 1,0 m
11.649 - 2,7 m
11.650 - 3,0 m

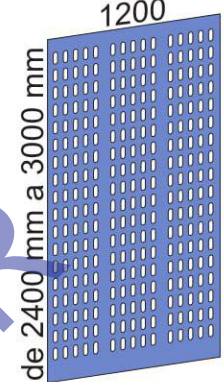

Chapa Logística
11.651 - 1,0 m
11.652 - 2,7 m
11.653 - 3,0 m

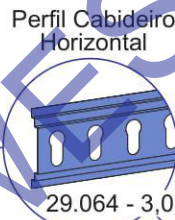

Perfil Cabideiro Horizontal
29.064 - 3,0 m



Paraf. Brocante
26.805

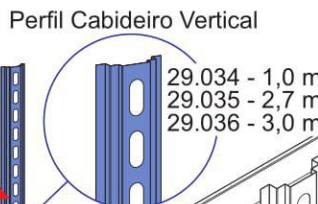
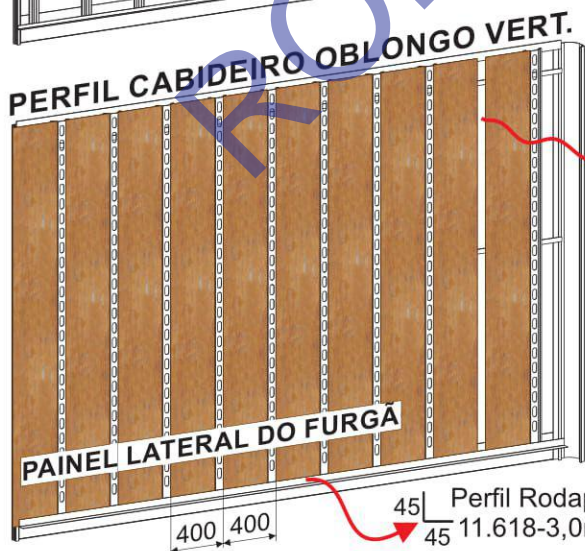
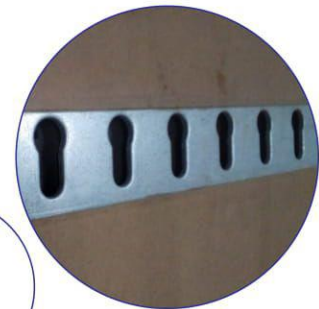

Perfil Cabideiro Vertical
29.034 - 1,0 m
29.035 - 2,7 m
29.036 - 3,0 m

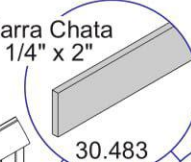

Barra Chata
1/4" x 2"
30.483



Paraf. Brocante
26.805

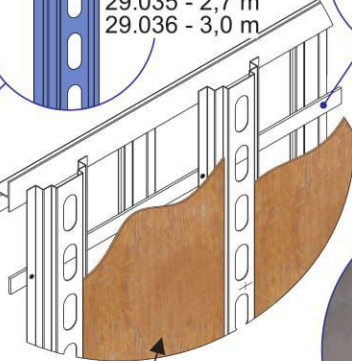

Placa Eucatex
Cod. - 34.082 marrom
Cod. - 34.080 cerejeira
Cod. - 34.081 neve

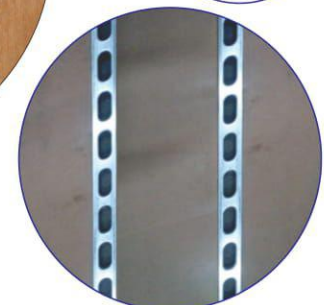

RODOWESSLER

PISO ROLETADO

CJ Piso Roletado

Roletes em Termoplástico

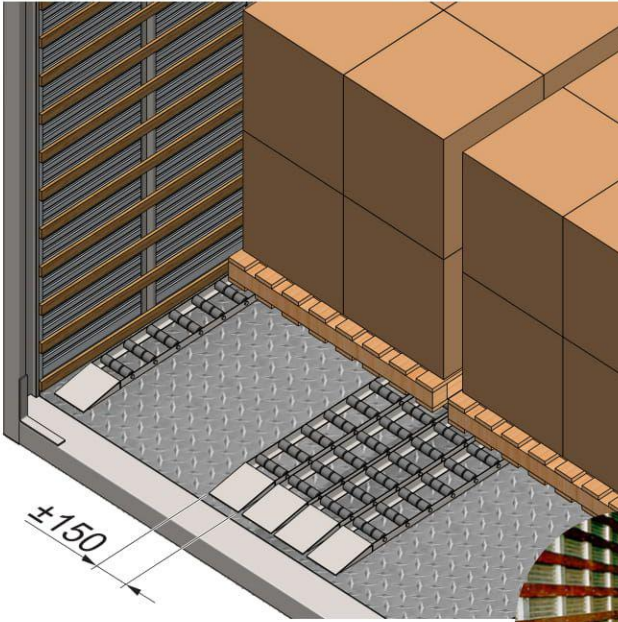

CJ Piso Roletado TPI Fixo - 411.003

CJ Piso Roletado

Roletes em Aço Galvanizado

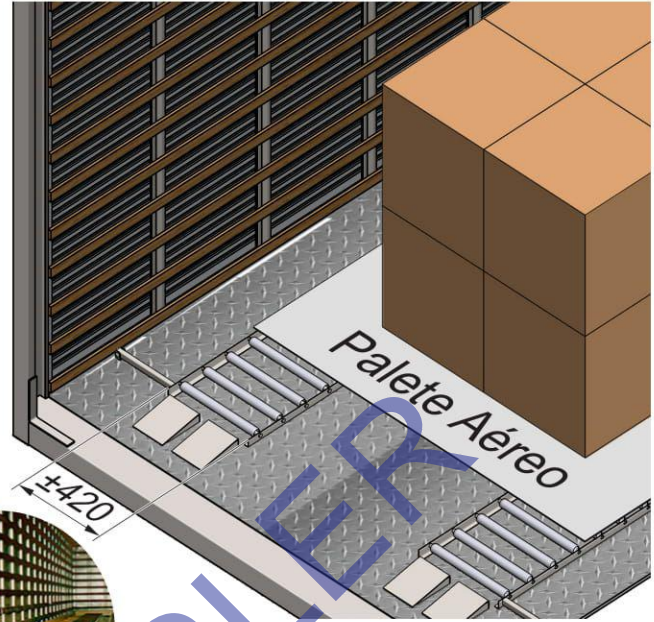

CJ Piso Roletado AG Fixo - 411.005

CJ Piso Roletado AG Artic. - 411.006

DIVISÓRIA DE CARGA

Kit Divisória de Carga

Modelo Trançado

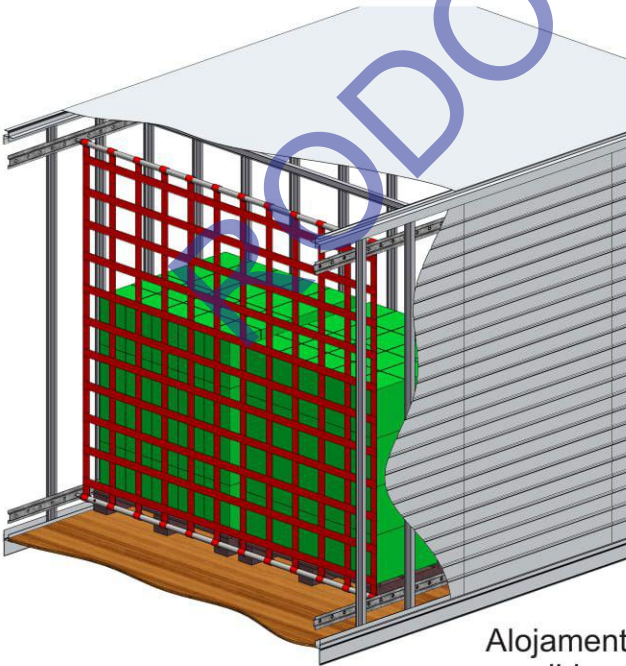

411.011

Kit Divisória de Carga

Modelo Fechado

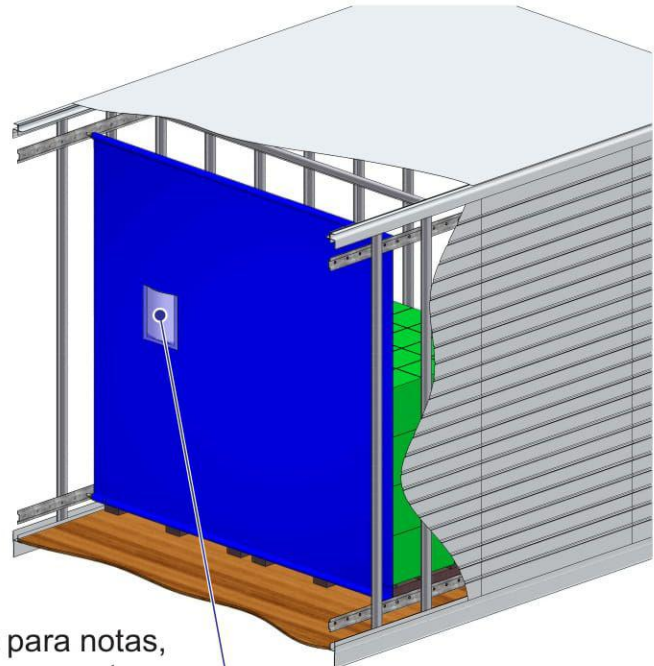

411.012

Alojamento para notas,
pedidos, orçamentos
e outros

RODOWESSLER

Peças para Implementos Rodoviários

Site: www.rodowessler.com.br
e-mail: vendas@rodowessler.com.br

Figuras e Fotos Meramente Ilustrativas.

(11) 2431-5300

M
U
L
T
I
M
A
R
C
A
S



PISO DOUBLE DECK PARA FURGÕES

Perfil Trilho DD

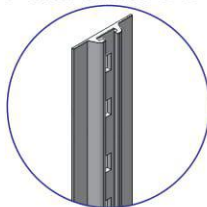

AL-100.061-1,8m
AG-22.786-1,8m

CJ Travessão
Double Deck

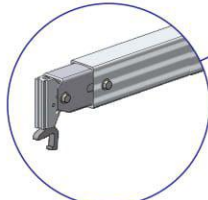

37.858 - AL
37.923 - AG

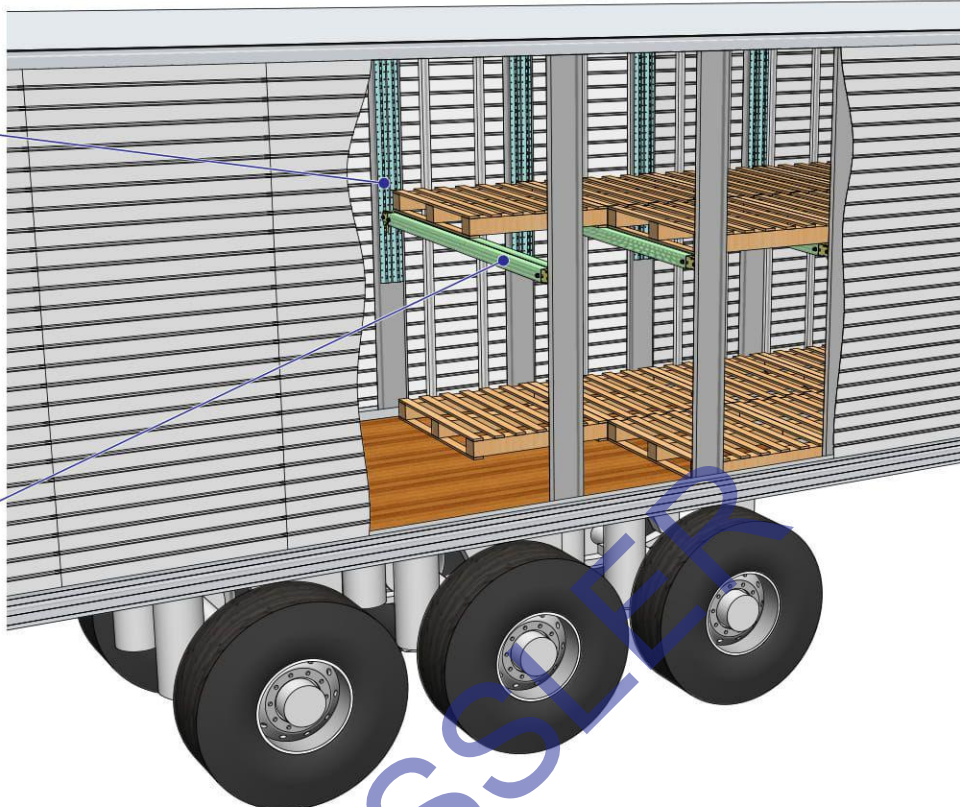

PISO DOUBLE DECK PARA SIDER

Perfil Trilho DD

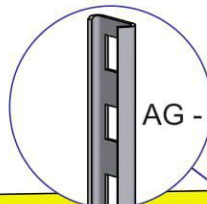

AG - 22.786 - 1,8m

CJ Travessa
Transversal DD

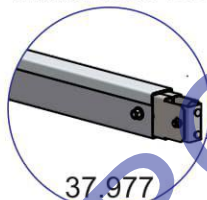

37.977

CJ Travessão
Longitudinal SD

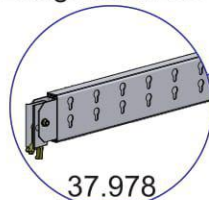

37.978

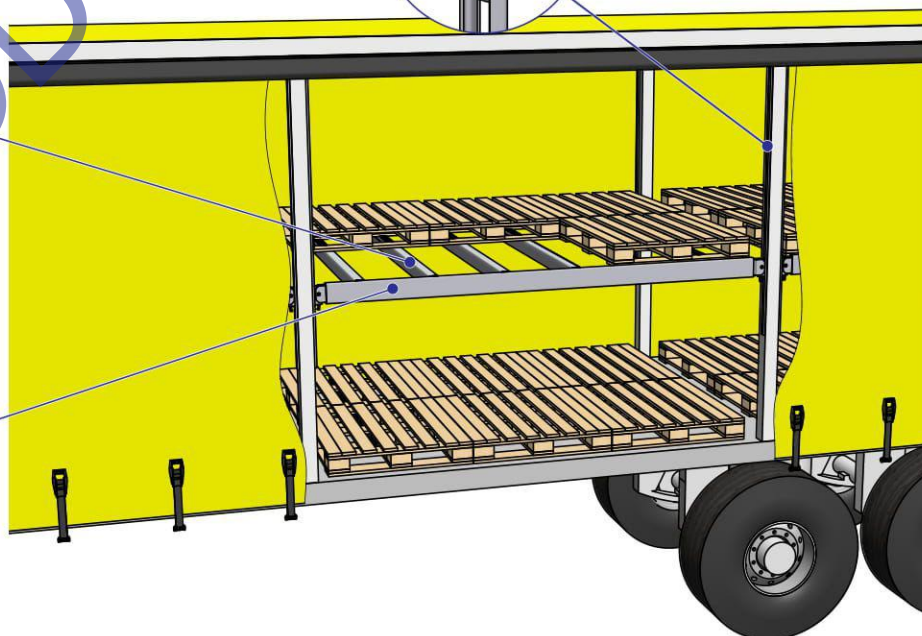

Figuras e Fotos Meramente Ilustrativas.

RODOWESSLER

Site: www.rodowessler.com.br
e-mail: vendas@rodowessler.com.br

(11) 2431-5300

PORTAS ROLL UP

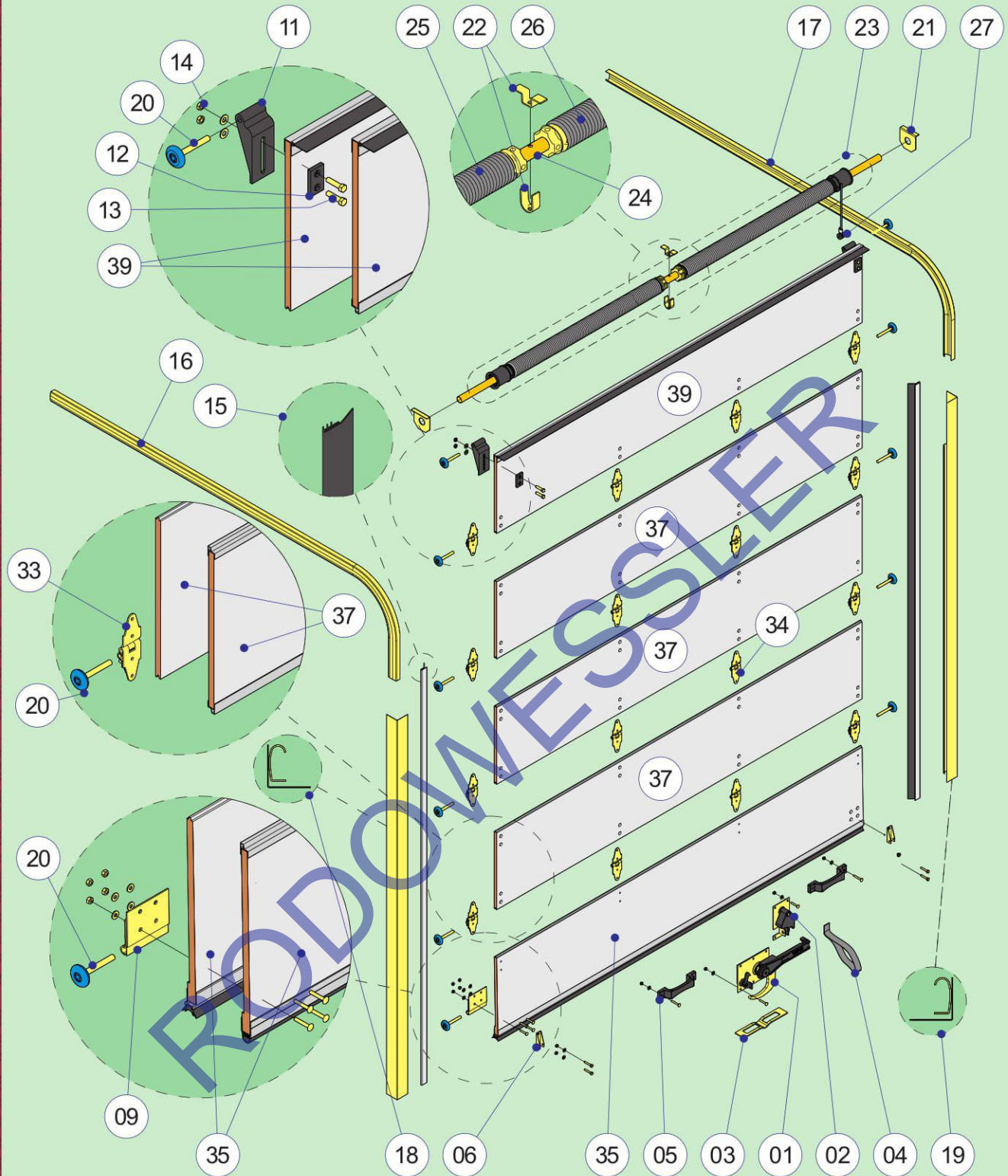

- | | | | |
|-----------------------|---------------------------|-----------------------|--------------------------|
| 01 - Trinco | 12 - Calço | 20 - Rodízio | 33 - Dobradiça Extremid. |
| 02 - Trava Trinco | 13 - Parafuso 3/8"x1 1/2" | 21 - Suporte Balancim | 34 - Dobradiça Interméd. |
| 03 - Engate do trinco | 14 - Porca 3/8" | 22 - Suporte Central | 35 - Cj Painel Inferior |
| 04 - Puxador | 15 - Vedação Lateral | 23 - Cj. Balancim | 37 - Cj Painel Interméd. |
| 05 - Pega Mão | 16 - Trilho Curvo Esq. | 24 - Tubo Balancim | 39 - Cj Painel Superior |
| 06 - Suporte Cabo | 17 - Trilho Curvo Dir. | 25 - Cj. Mola Esq. | |
| 09 - Suporte Rodízio | 18 - Trilho Reto Esq. | 26 - Cj. Mola Dir. | |
| 11 - Suporte Rod.Sup. | 19 - Trilho Reto Dir. | 27 - Cabo de Aço | |

M
U
L
T
I
M
A
R
C
A
S

Figuras e Fotos Meramente Ilustrativas.

RODOWESSLER

Peças para Implementos Rodoviários

Site: www.rodowessler.com.br
e-mail: vendas@rodowessler.com.br

(11) 2431-5300



PORTAS ROLL UP WPR

RODOWESSLER

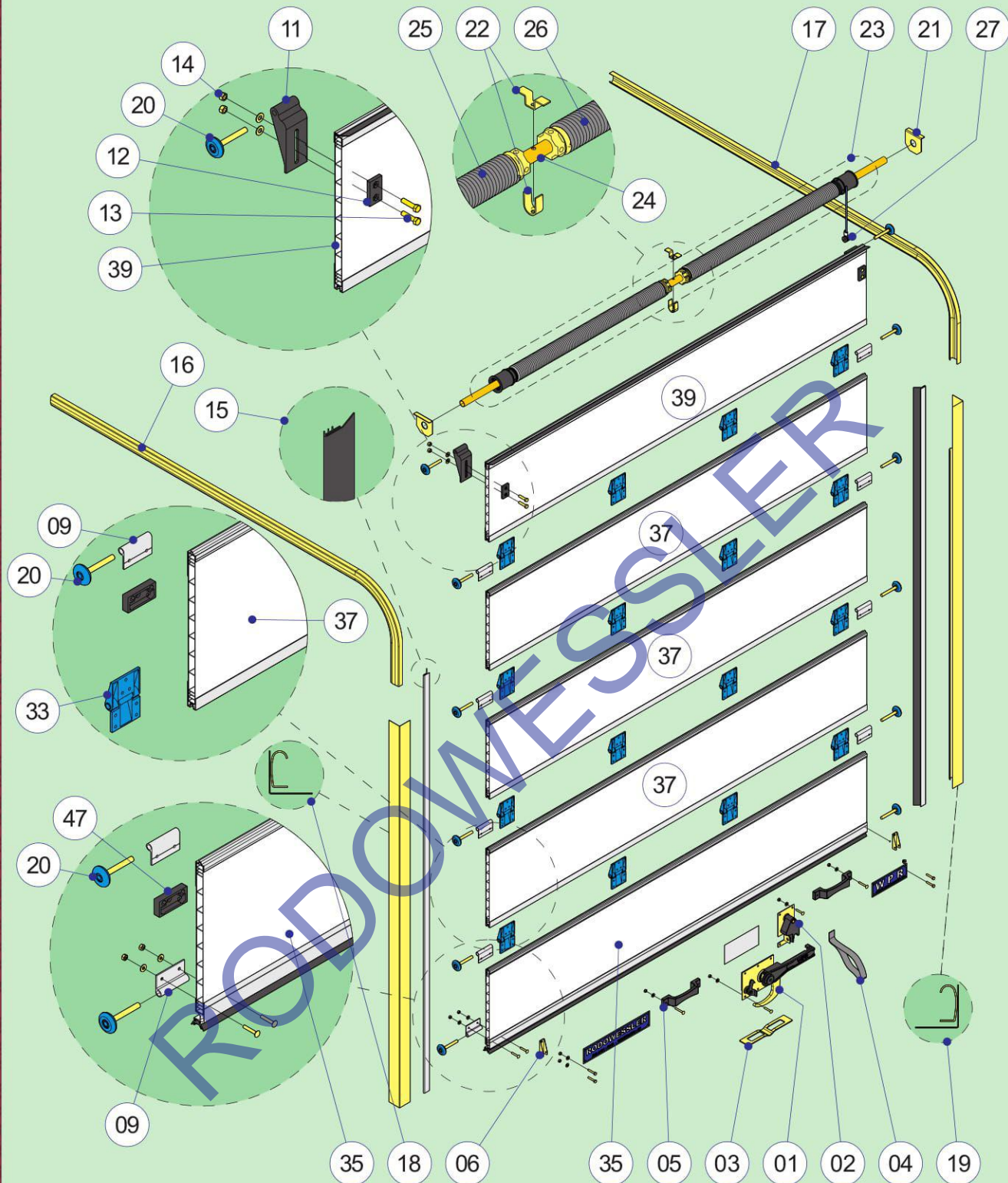

- | | | | |
|-----------------------|---------------------------|-----------------------|--------------------------|
| 01 - Trinco | 12 - Calço | 20 - Rodízio | 33 - Dobradiça |
| 02 - Trava Trinco | 13 - Parafuso 3/8"x1 1/2" | 21 - Suporte Balancim | 35 - Cj Painel Inferior |
| 03 - Engate do trinco | 14 - Porca 3/8" | 22 - Suporte Central | 37 - Cj Painel Intermed. |
| 04 - Puxador | 15 - Vedação Lateral | 23 - Cj. Balancim | 39 - Cj Painel Superior |
| 05 - Pega Mão | 16 - Trilho Curvo Esq. | 24 - Tubo Balancim | 47 - Suporte Interno |
| 06 - Suporte Cabo | 17 - Trilho Curvo Dir. | 25 - Cj. Mola Esq. | |
| 09 - Suporte Rodízio | 18 - Trilho Reto Esq. | 26 - Cj. Mola Dir. | |
| 11 - Suporte Rod.Sup. | 19 - Trilho Reto Dir. | 27 - Cabo de Aço | |

Figuras e Fotos Meramente Ilustrativas.

RODOWESSLER

Site: www.rodowessler.com.br
e-mail: vendas@rodowessler.com.br

(11) 2431-5300

048

Peças para Implementos Rodoviários

RODOWESSLER®

REFERÊNCIA EM PEÇAS PARA IMPLEMENTOS

PORTAS CONVENCIONAIS



Obtenha o melhor custo-benefício com as portas Rodowessler. Leveza, resistência, perfeito acabamento e versatilidade. Tanto para medidas padrões, como projetos especiais.

PORTA CONVENCIONAL

A
N
T
O
N
I
N
I

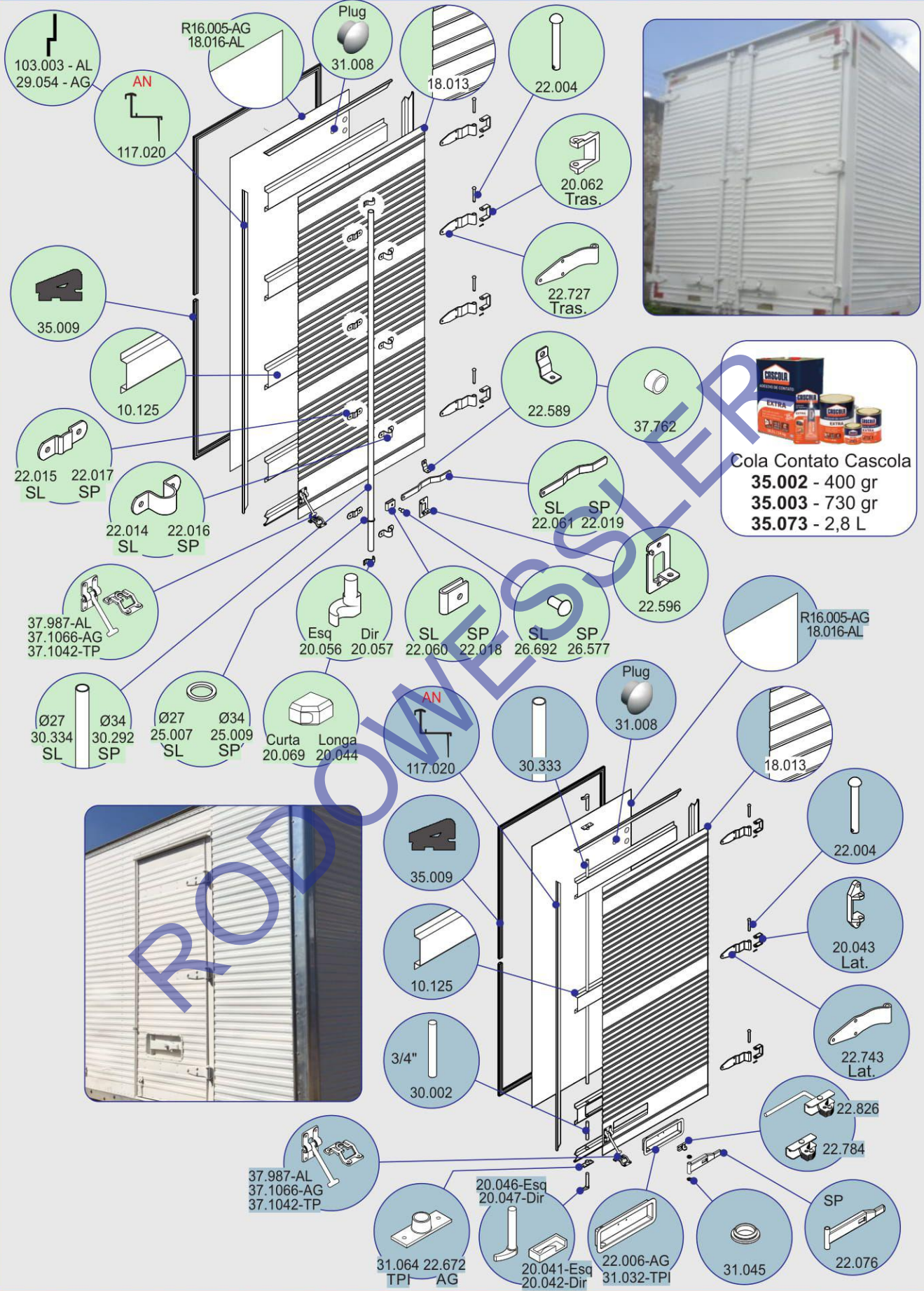

Cola Contato Cascola
35.002 - 400 gr
35.003 - 730 gr
35.073 - 2,8 L



Figuras e Fotos Meramente Ilustrativas.



PORTA CONVENCIONAL

BERTOLINI * CARGO VAN * GALEGO * METALCAR * QUALITAS * 4 TRUCK

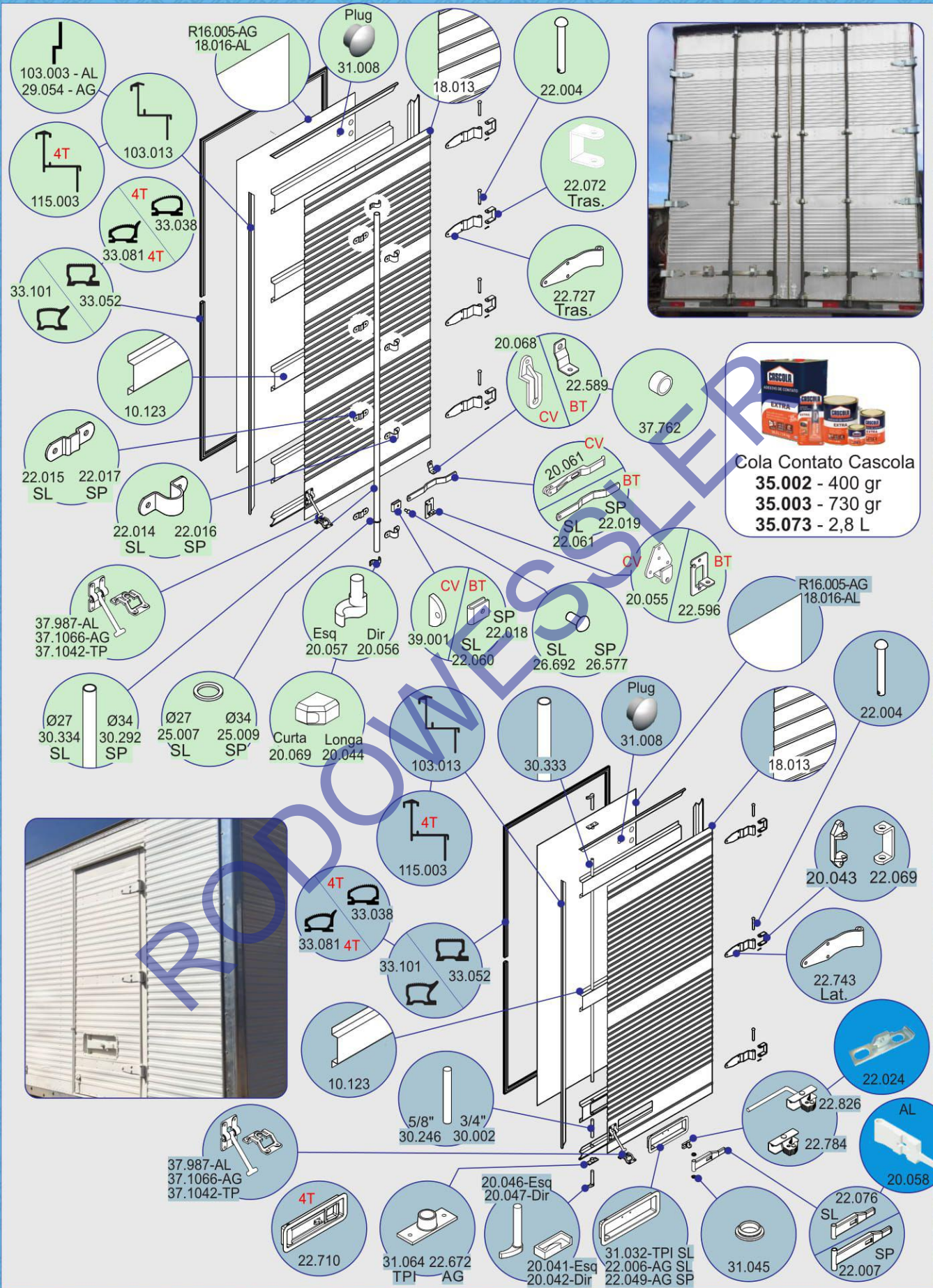

Cola Contato Cascola
35.002 - 400 gr
35.003 - 730 gr
35.073 - 2,8 L

Figuras e Fotos Meramente Ilustrativas.

PORTA CONVENCIONAL

C
A
R
B
U
S

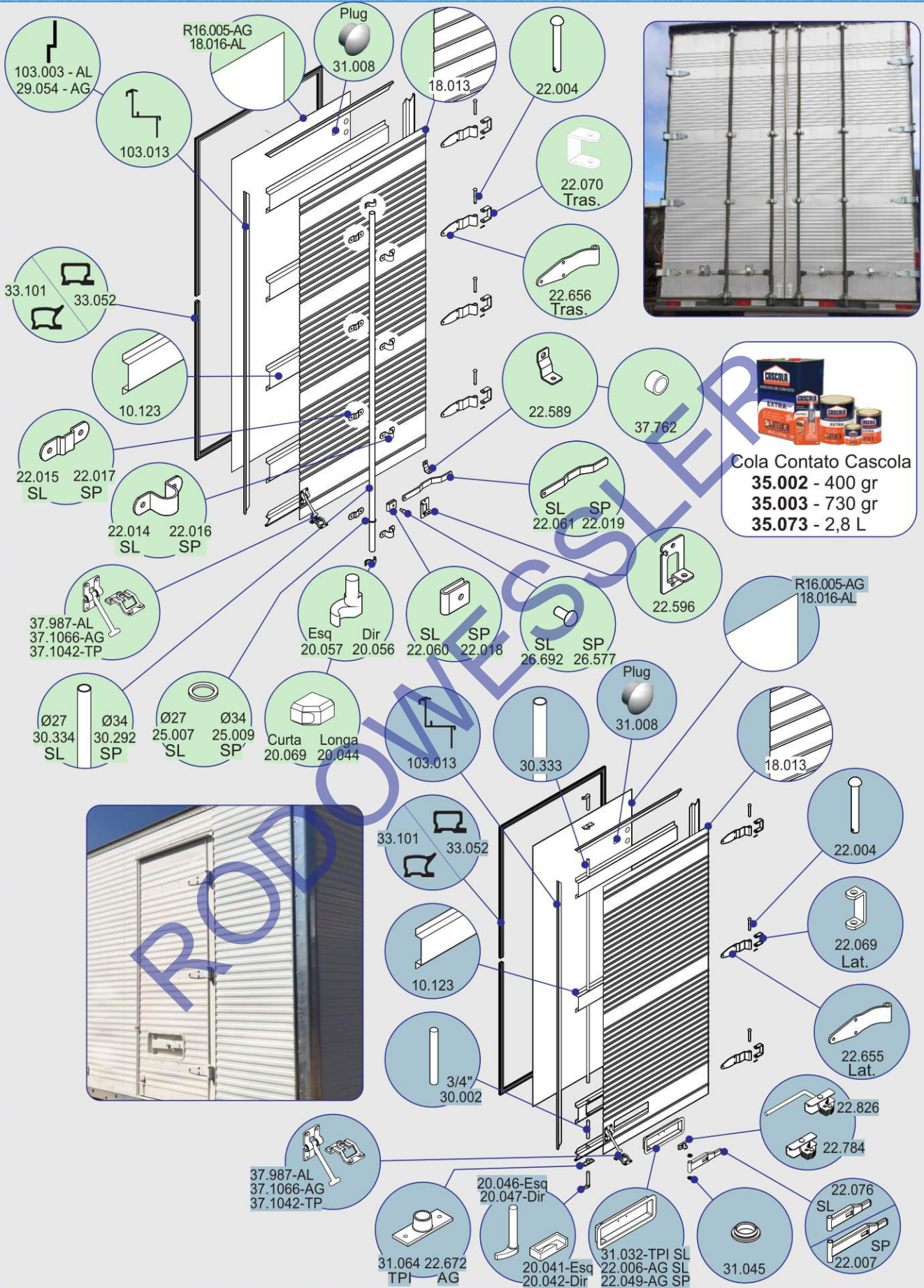

Figuras e Fotos Meramente Ilustrativas.



PORTA CONVENCIONAL

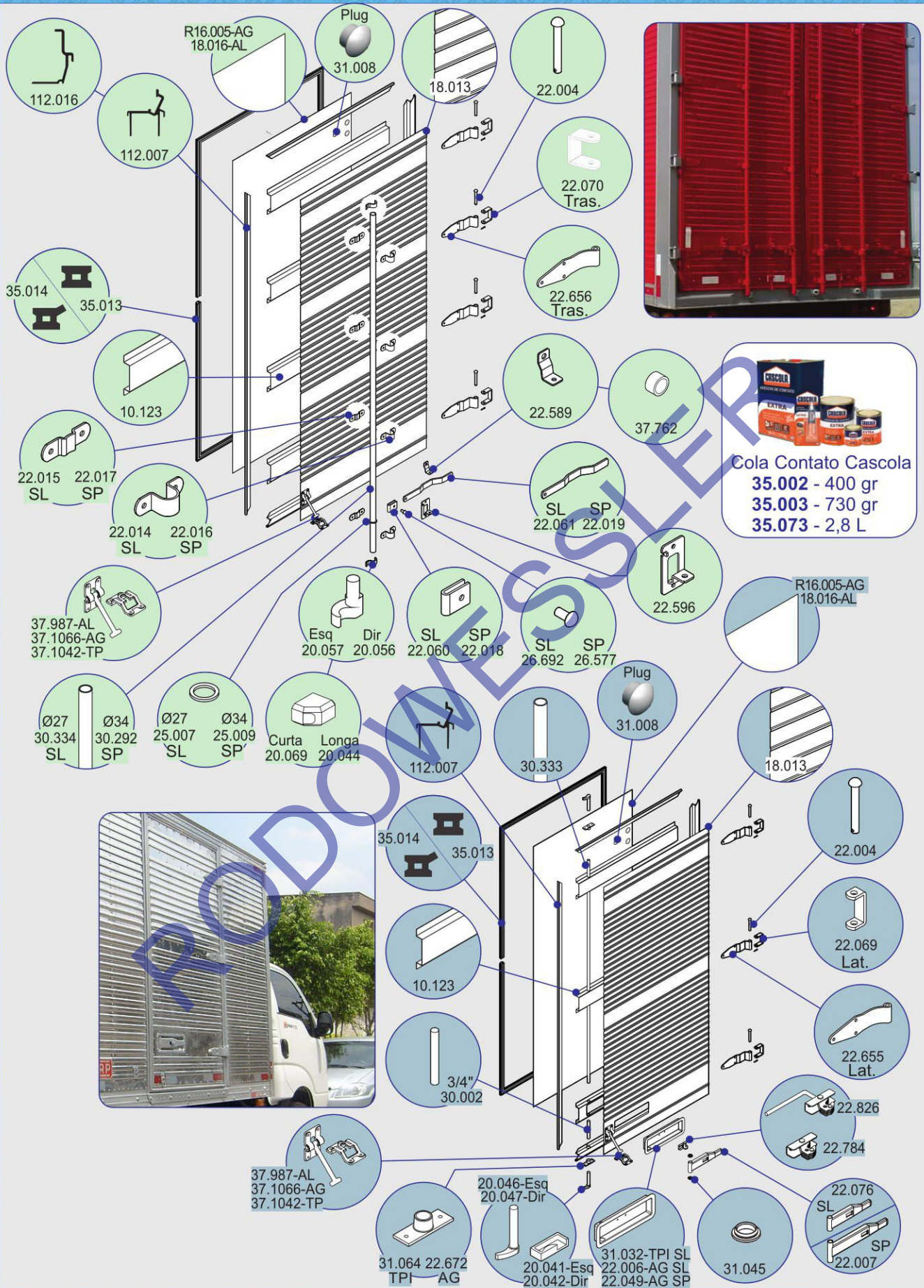

E
D
A
R
P

Figuras e Fotos Meramente Ilustrativas.

PORTA CONVENCIONAL

F
A
C
C
H
I
N
I
S

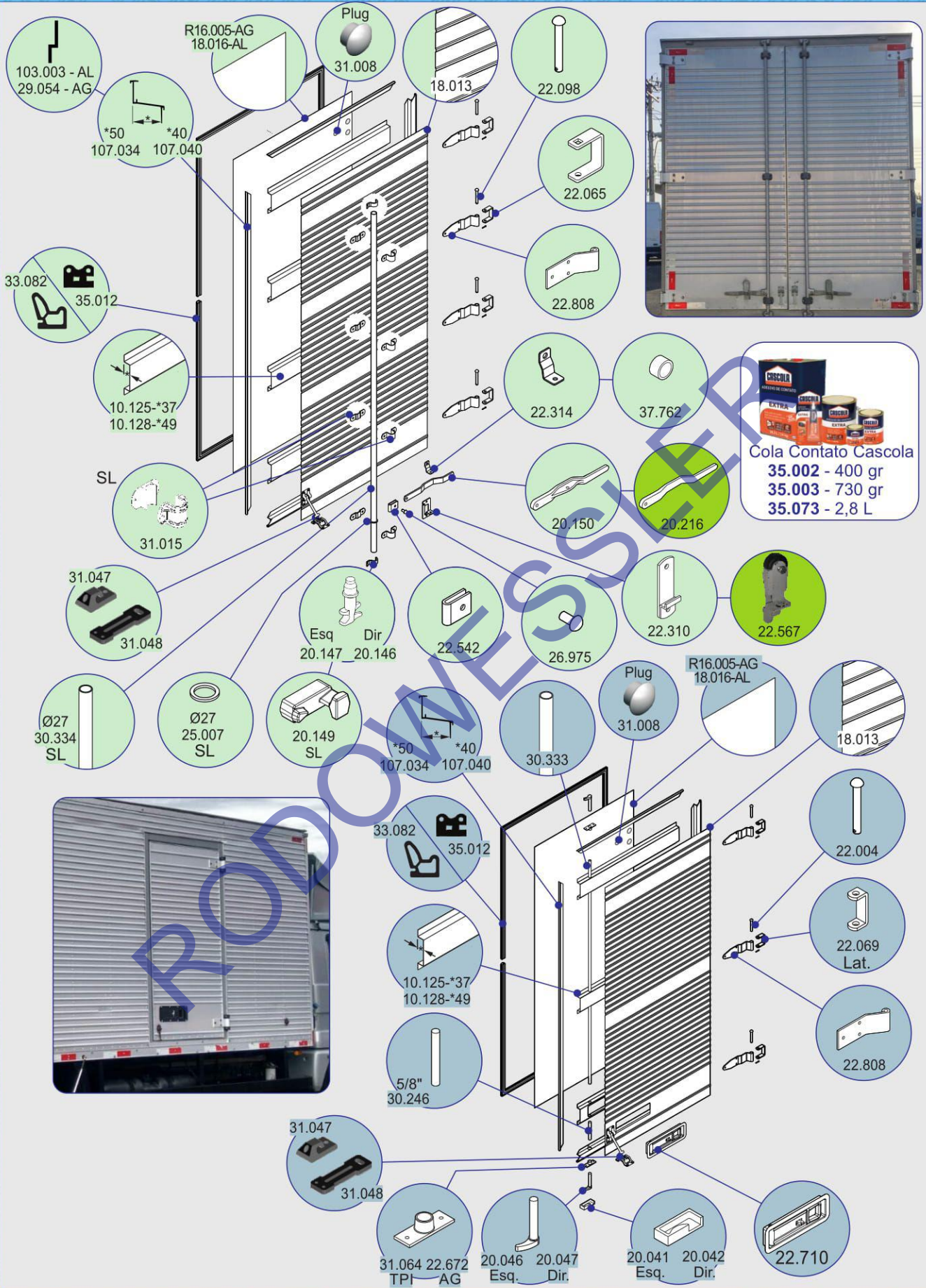

Figuras e Fotos Meramente Ilustrativas.

PORTA CONVENCIONAL

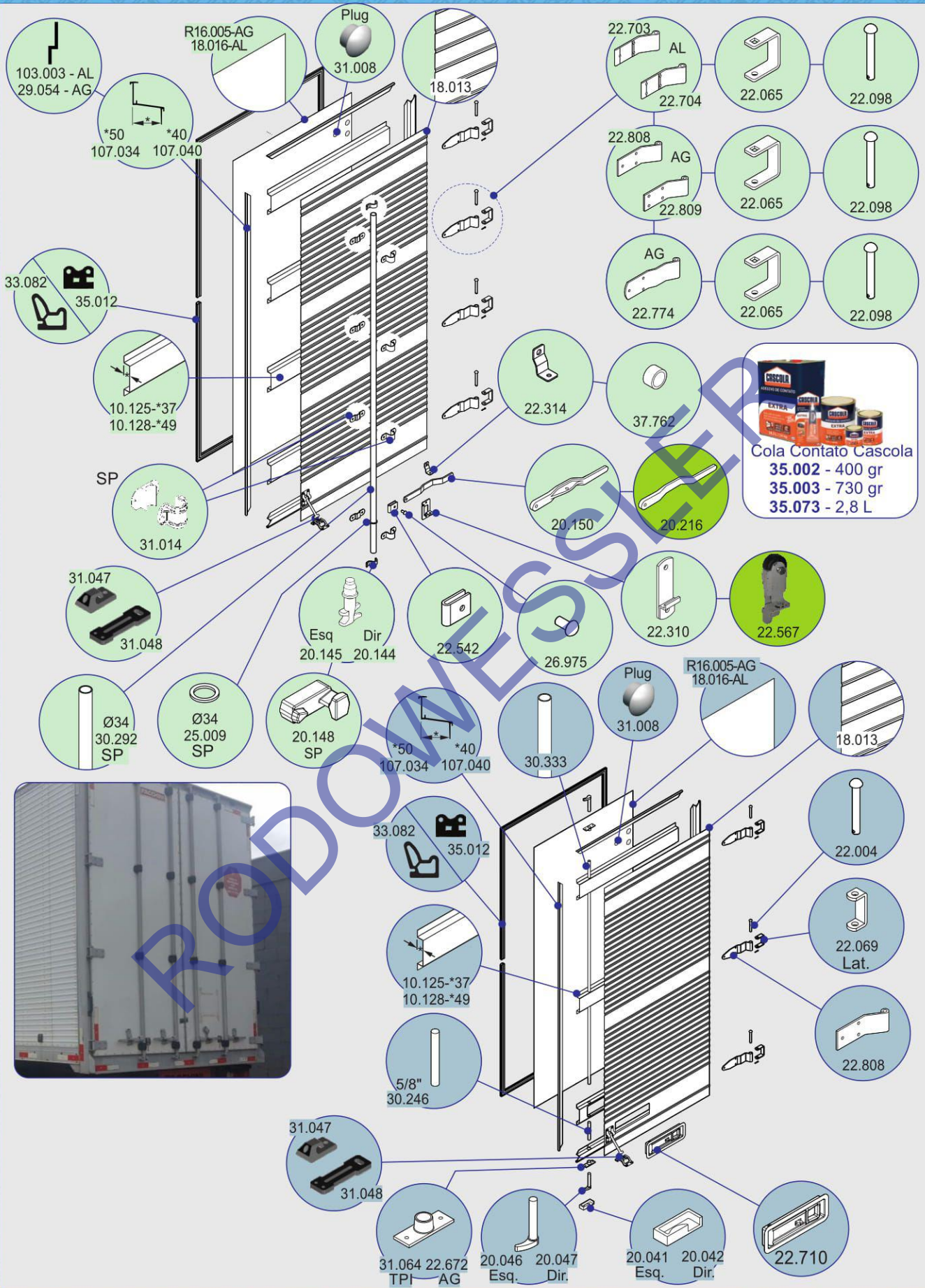

F
A
C
I
L
I
N
I
S
P

PORTA CONVENCIONAL

F
A
C
I
L
I
N
I

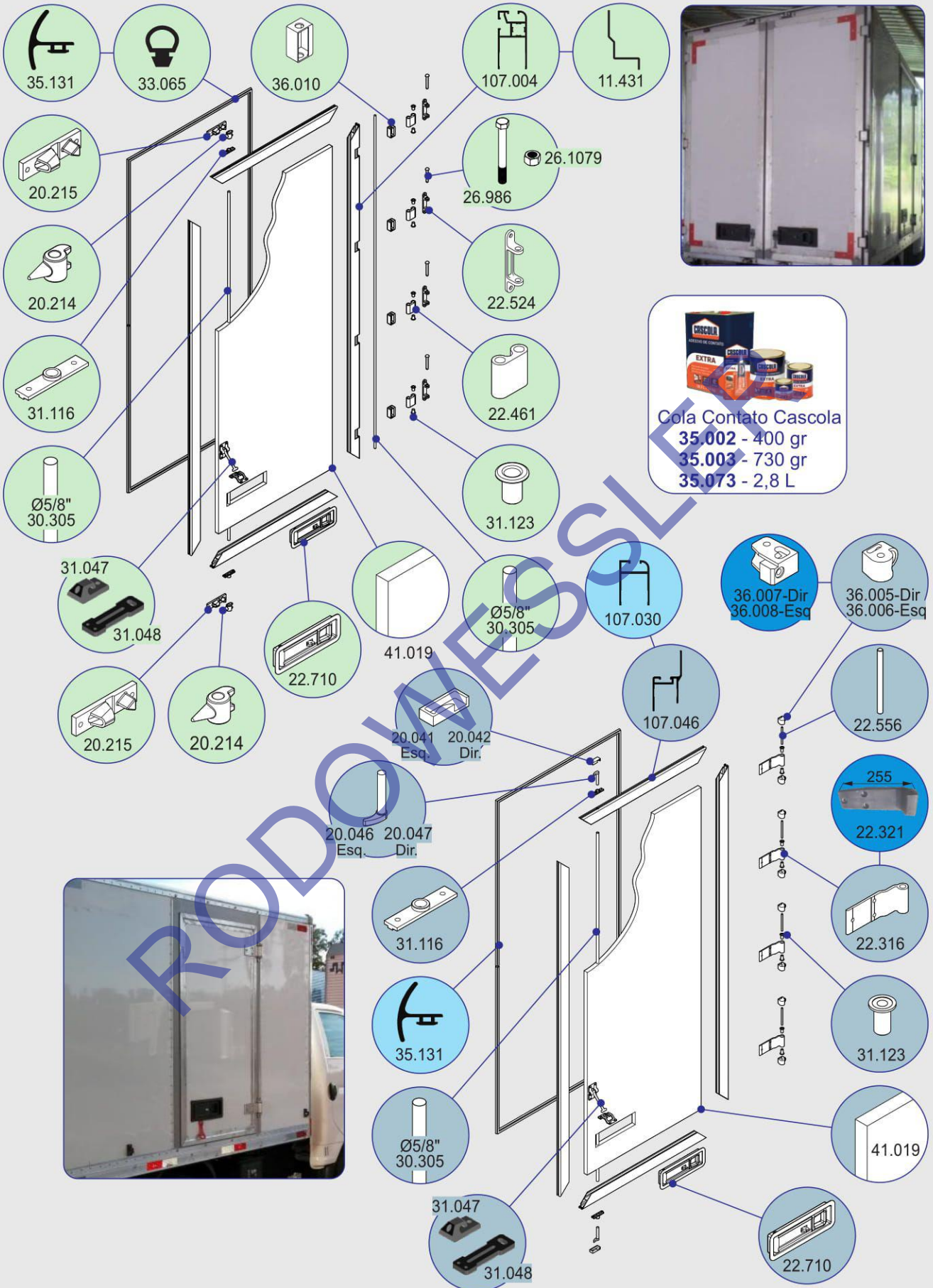

Cola Contato Cascola
35.002 - 400 gr
35.003 - 730 gr
35.073 - 2,8 L



Figuras e Fotos Meramente Ilustrativas.

PORTA CONVENCIONAL

FACCHINI RODOFORT

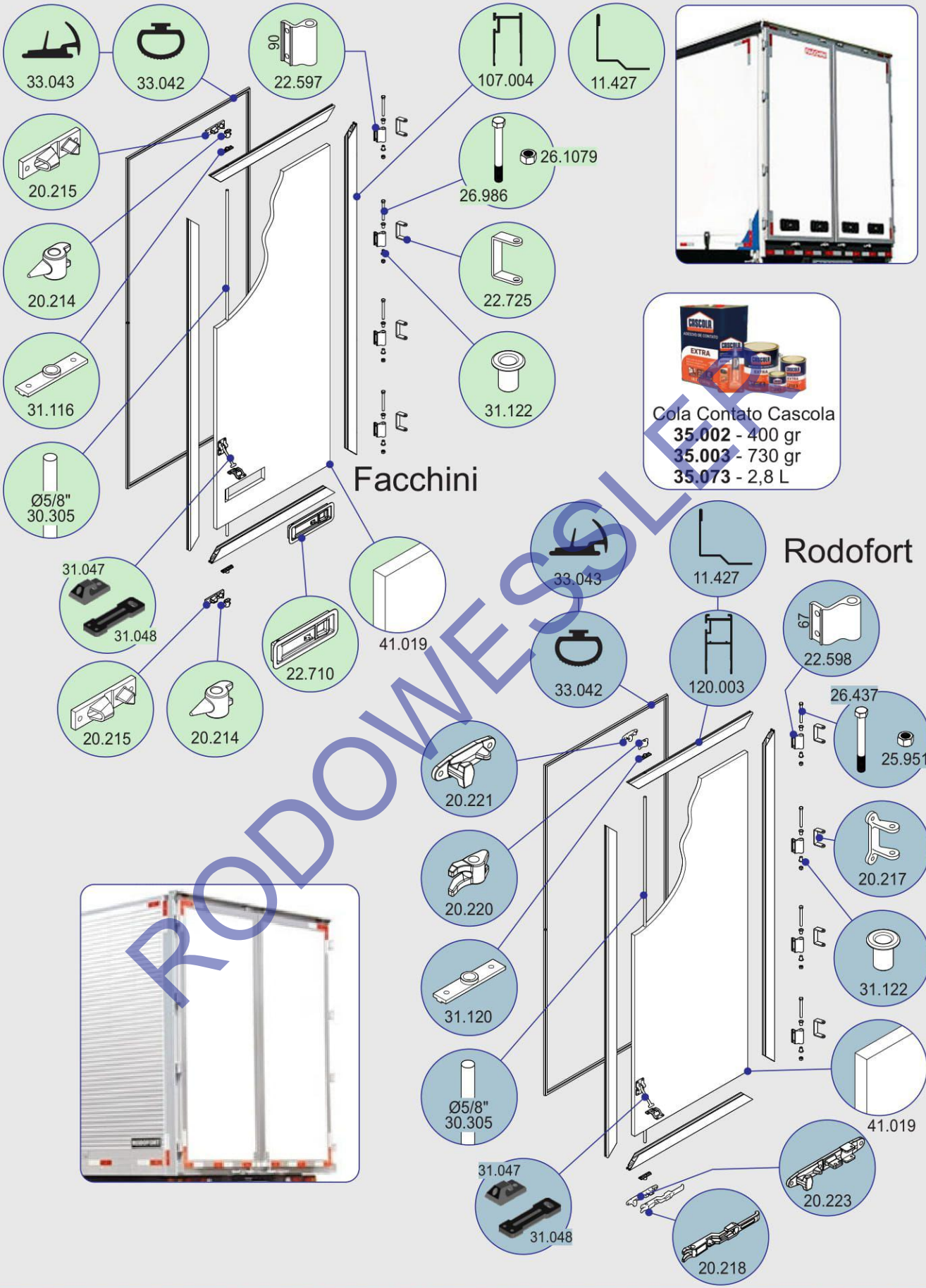

Cola Contato Cascola
35.002 - 400 gr
35.003 - 730 gr
35.073 - 2,8 L

Rodofort



PORTA CONVENCIONAL

GUERRA

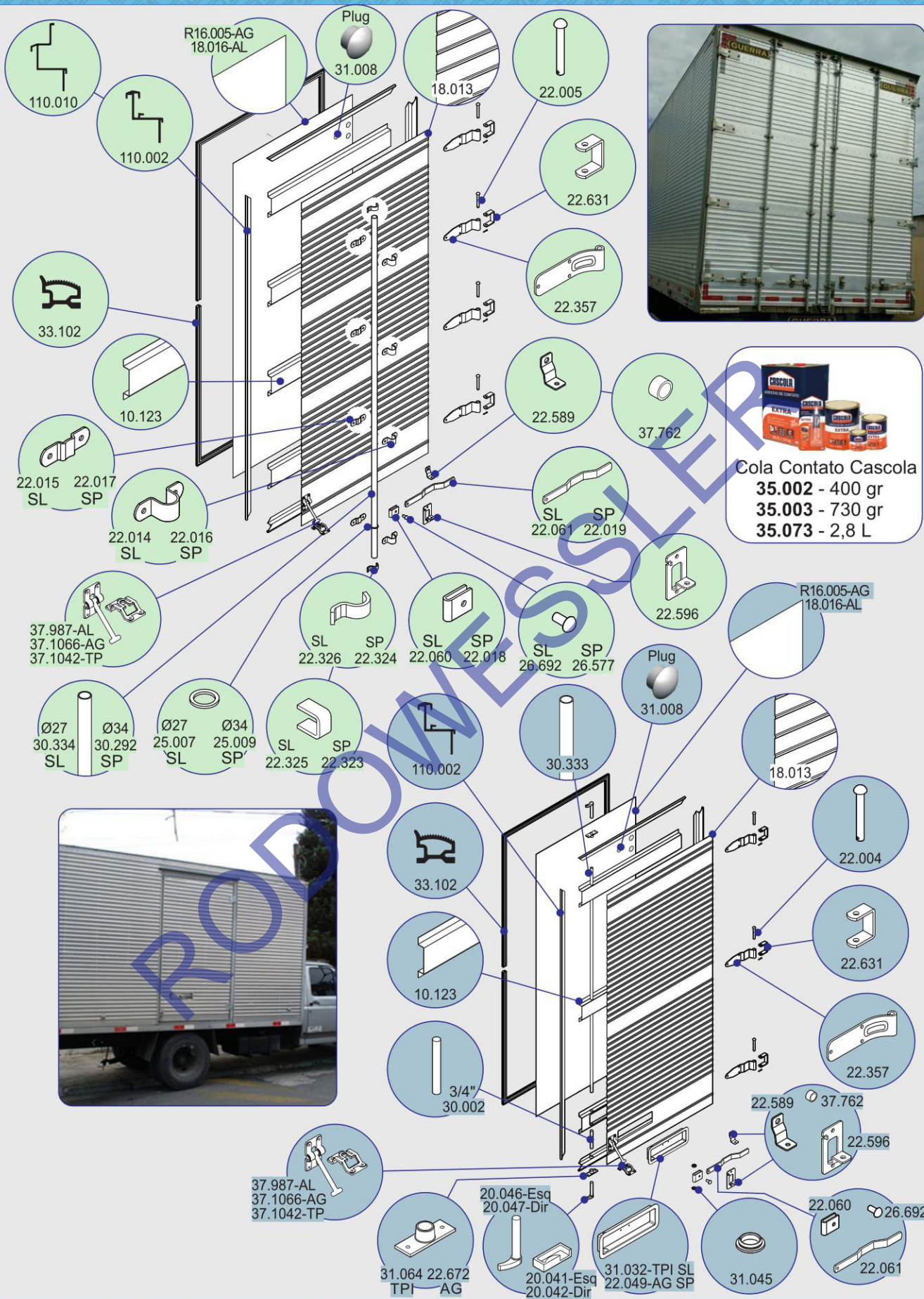

Cola Contato Cascola
35.002 - 400 gr
35.003 - 730 gr
35.073 - 2,8 L



Figuras e Fotos Meramente Ilustrativas.

PORTA CONVENCIONAL

I
D
E
R
O
L
*
R
O
S
S
E
I
E
I

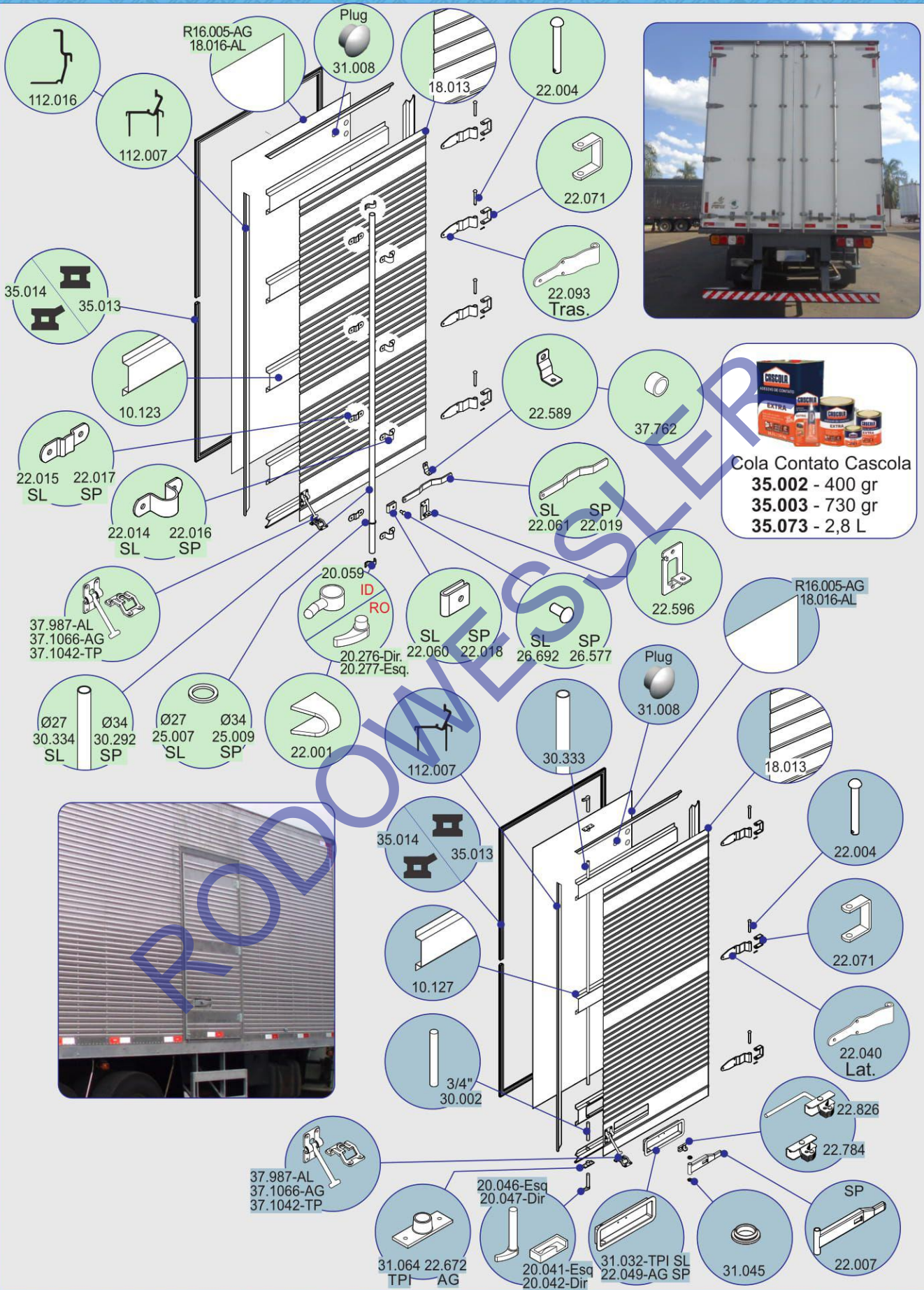

PORTA CONVENCIONAL

R
A
N
D
O
N

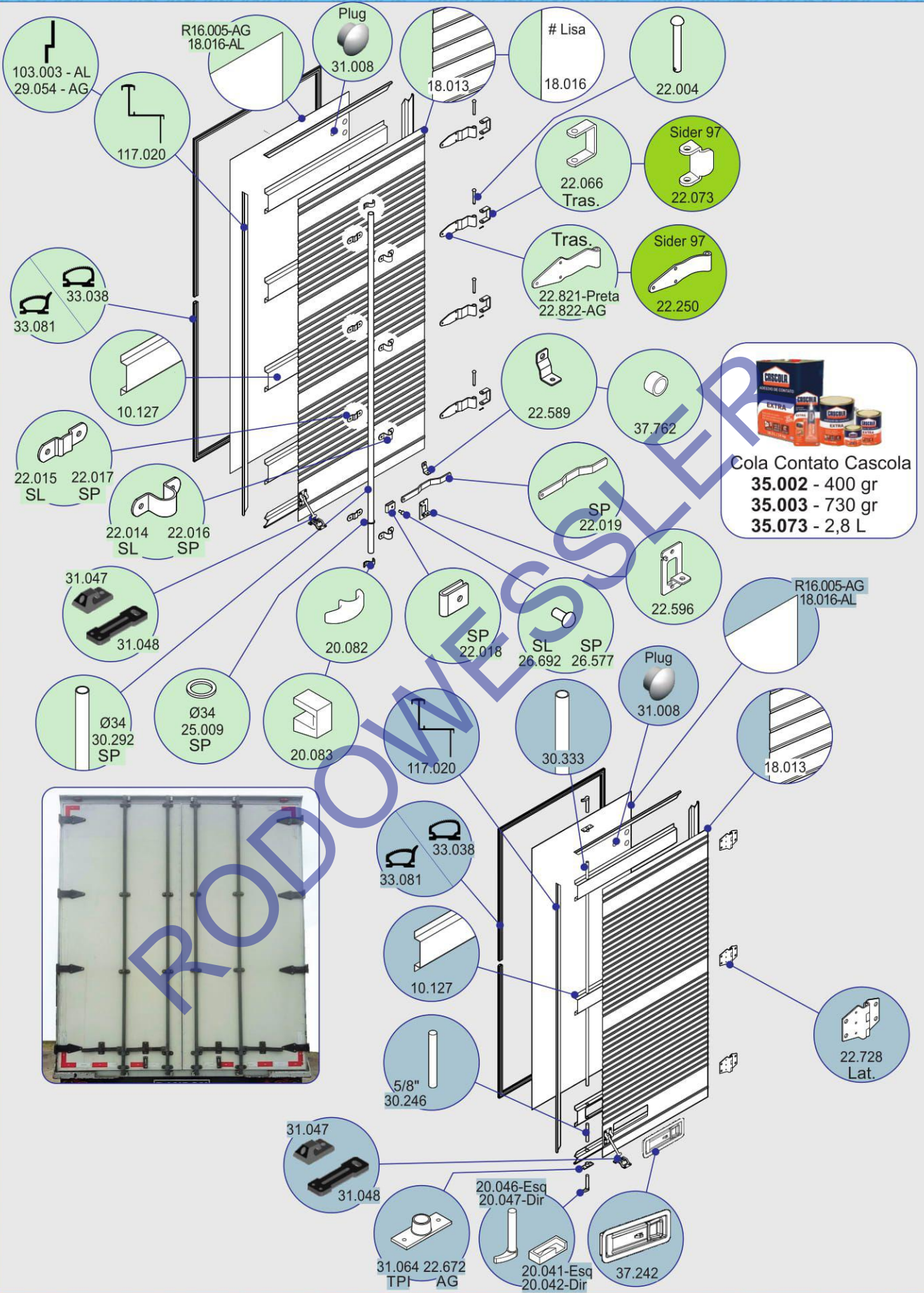

Figuras e Fotos Meramente Ilustrativas.



PORTA CONVENCIONAL

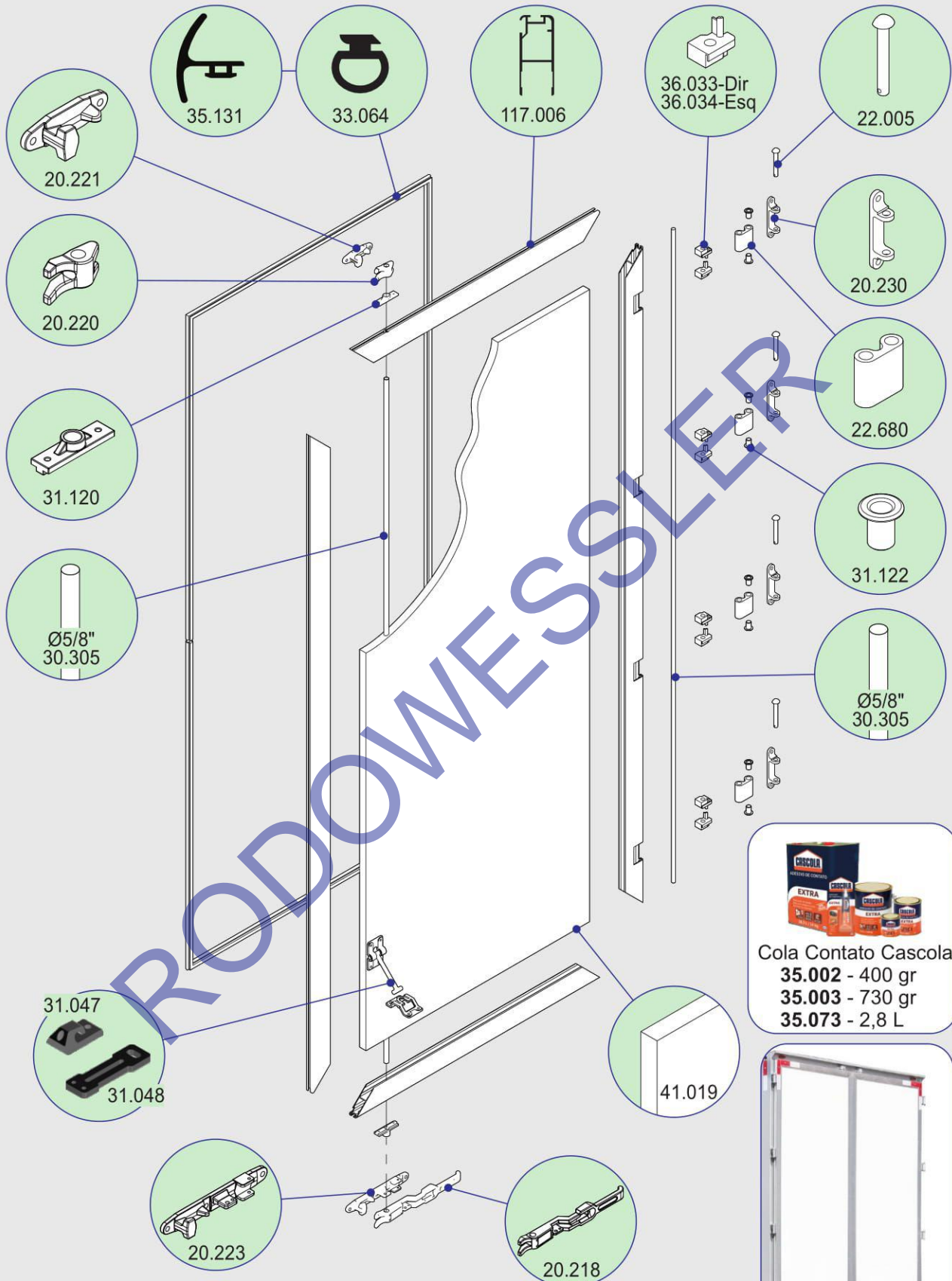

Cola Contato Cascola
 35.002 - 400 gr
 35.003 - 730 gr
 35.073 - 2,8 L



Figuras e Fotos Meramente Ilustrativas.

R
A
N
D
O
N

PORTA CONVENCIONAL

RODOWESSLER

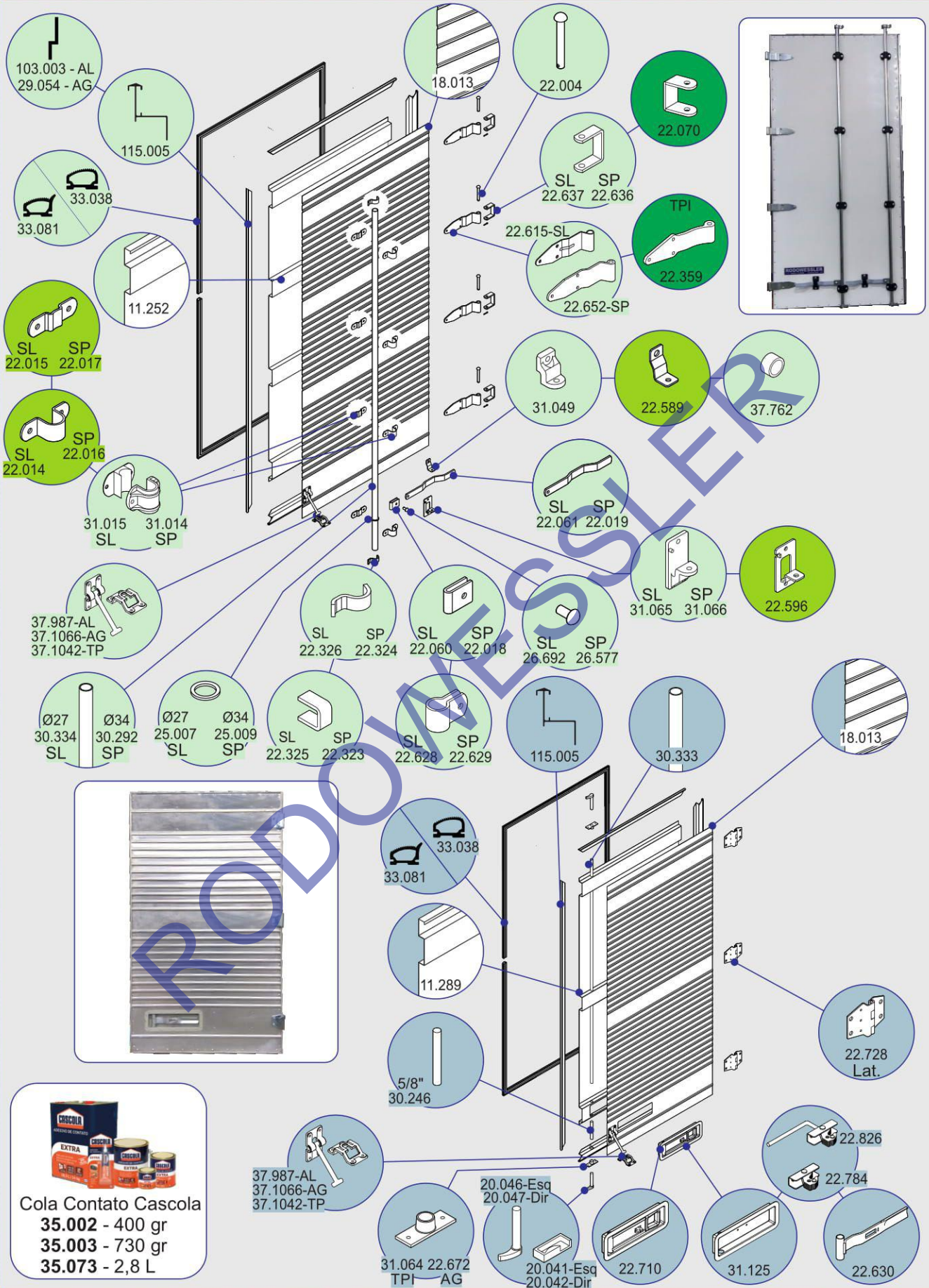

Cola Contato Cascola
35.002 - 400 gr
35.003 - 730 gr
35.073 - 2,8 L

Figuras e Fotos Meramente Ilustrativas.

RODOWESSLER
 REFERÊNCIA EM PEÇAS PARA IMPLEMENTOS

Site: www.rodowessler.com.br
 e-mail: vendas@rodowessler.com.br









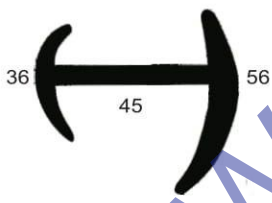

(11) 2431-5300

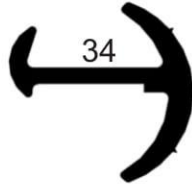

DOBRADIÇAS E GONZOS

 <p>Dobradiça Multmarcas 230 mm 22.244</p>	 <p>Dobradiça Multmarcas 180 mm 22.246</p>	 <p>Dobradiça Multmarcas 287 mm 22.251</p>	 <p>Dobradiça Caixa de Ferramenta AG 22.144</p>
 <p>Dobradiça Para Choque Móvel AG 22.162</p>	 <p>Dobradiça Para Choque Móvel AG 22.825</p>	 <p>Dobradiça Plana Porta Lateral Inox 22.258</p>	 <p>Gonzo 37.139 - 3/8" 37.140 - 1/2" 37.141 - 5/8" 37.142 - 3/4" 37.302 - 7/8" 37.303 - 1"</p>

PERFIS DE VEDAÇÃO MACIÇA E ESPONJOSA

 <p>Perfil Vedação PFR B 35.058 - 1,0 m</p>	 <p>Perfil Vedação PFR B 35.061 - 1,0 m</p>	 <p>Perfil Vedação PFR RD B 35.087 - 1,0 m</p>	 <p>Perfil Vedação PFR B 35.088 - 1,0 m</p>
 <p>Perfil Vedação PFR FC B 35.094 - 1,0 m</p>	 <p>Perfil Vedação PI RW TPF 33.011 - 1,0 m</p>	 <p>Perfil Vedação PI RW TPF 33.012 - 1,0 m</p>	 <p>Perfil Vedação PFR RW 34 mm TPF 33.048 - 1,0 m</p>
 <p>Perfil Junção 70 RW TPF 33.032 - 1,0 m</p>	<p>Duplo Simples</p>  <p>Perfil Vedação PFR RW/RC TPF Duplo - 33.010 - 1,0 m Simples- 33.023 - 1,0 m</p>	 <p>Perfil Vedação LS ESP 35.098 - 1,0 m</p>	 <p>Perfil Vedação ESP 15x15 - 35.110 - 1,0m 25x12,5 - 35.091 - 1,0m 25x19 - 35.071 - 1,0m 50x25 - 35.076 - 1,0m</p>

Figuras e Fotos Meramente Ilustrativas.

RODOWESSLER

Peças para Implementos Rodoviários

Site: www.rodowessler.com.br
e-mail: vendas@rodowessler.com.br

(11) 2431-5300

M
U
L
T
I
M
A
R
C
A
S



COMPONENTES PORTA FRIGORÍFICA SL -SP

RODOWESSLER



Cola Contato Cascola
 35.002 - 400 gr
 35.003 - 730 gr
 35.073 - 2,8 L

Ø20 22.576
 Ø25 22.578

22.262

Ø20 30.075
 Ø25 30.076

Ø20 26.820
 Ø25 26.821

37.1076
 Inox

Ø20 20.166
 Ø25 20.168

Ø20 20.167
 Ø25 20.165

22.581

26.774 26.966

230
 SL 22.802

285
 SP 22.799

31.123

SL M10x115 26.773
 SP M10x130 26.914

SL 22.803
 SP 22.800

26.073
 26.774

Inox
 22.829

22.590

37.762

22.585

22.588

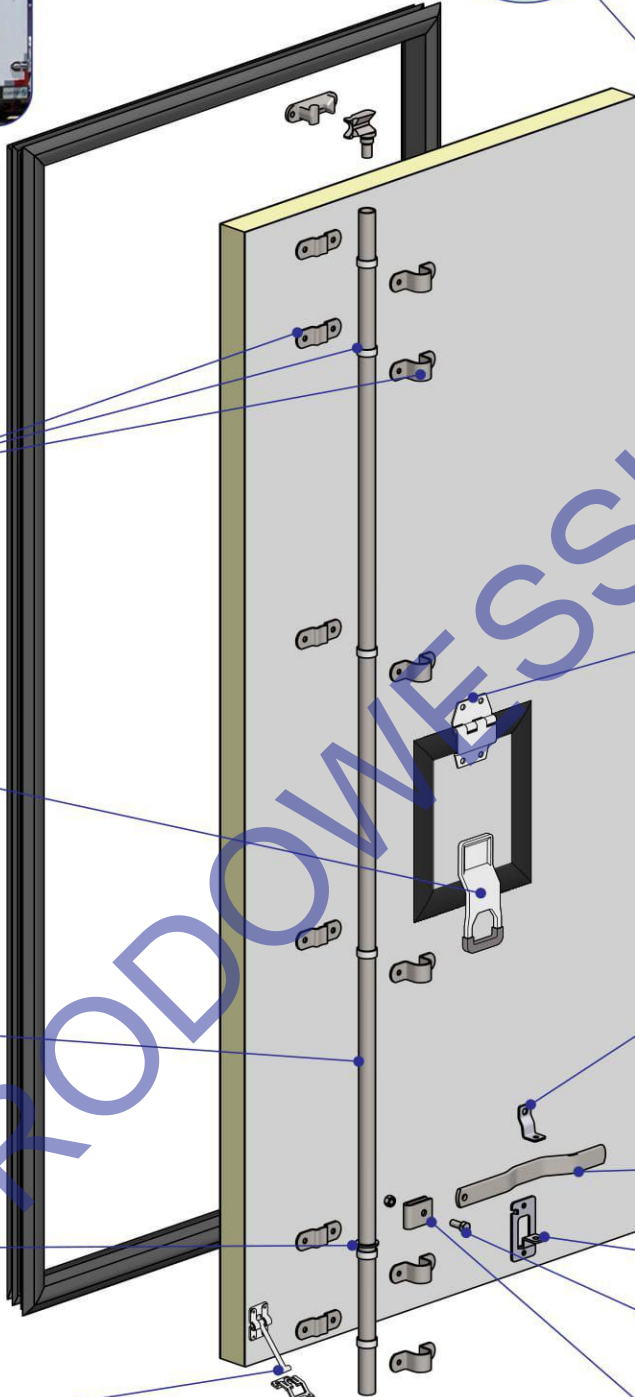

Figuras e Fotos Meramente Ilustrativas.

COMPONENTES PORTA FRIGORÍFICA

M
U
L
T
M
A
R
C
A
S

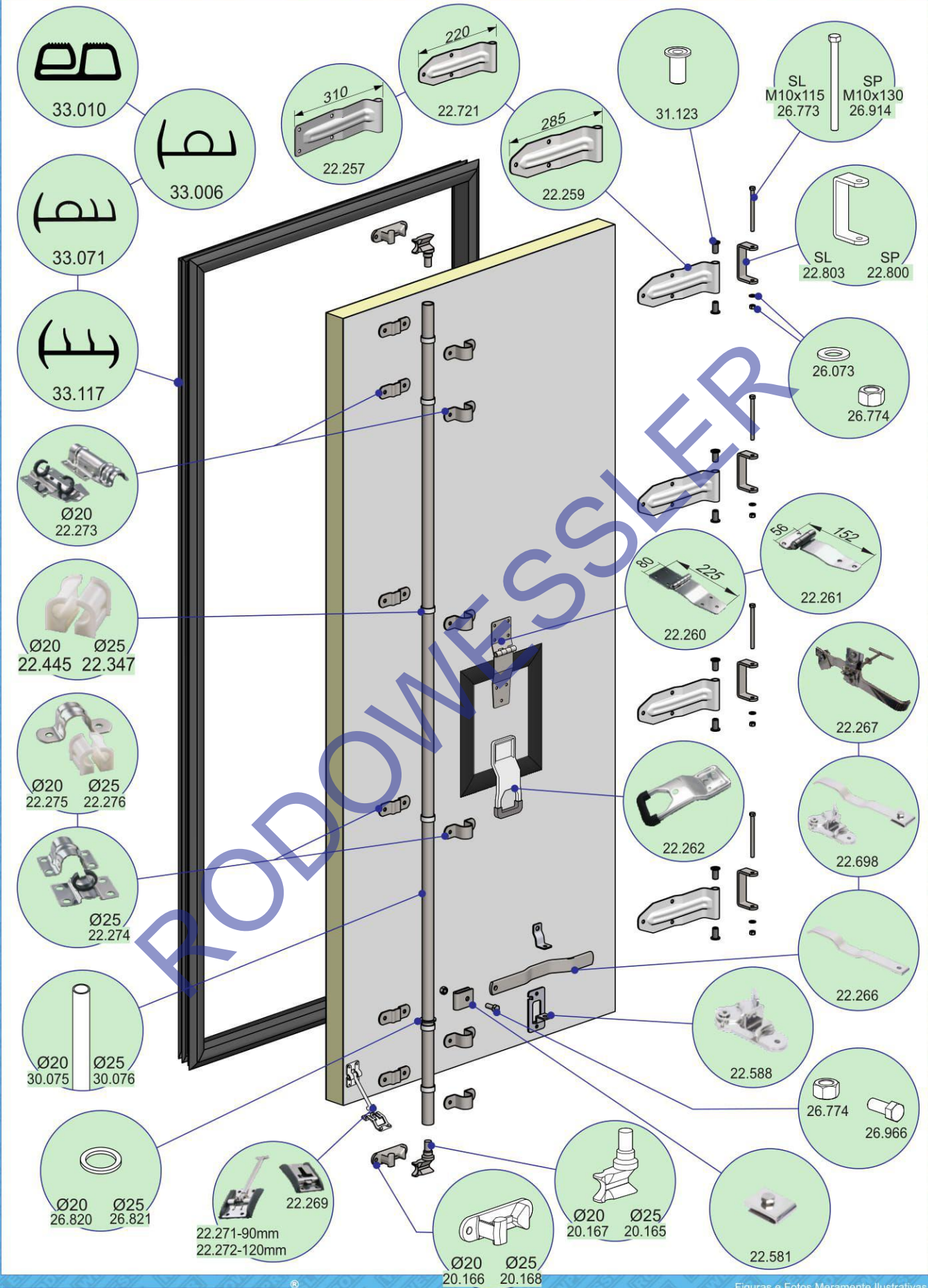

ACESSÓRIOS DE INOX

M
U
L
T
I
M
A
R
C
A
S

<p>Lingueta Inox Caixa do came Inox</p>  <p>Lingueta - 20.169 Caixa - 20.170 - Dir. Caixa - 20.171 - Esq.</p>	<p>V.I.</p>  <p>Bandeja Inox Trinco 16mm com Chave 22.559</p>	<p>V.E.</p>  <p>Bandeja Inox Trinco com Chave 22.557 - 19 mm 22.569 - 25 mm</p>	<p>V.I.</p>  <p>Bandeja Inox 16 mm com Chave e Tampa 22.263</p>
<p>V.E.</p>  <p>Trinco Inox SR 25mm com Chave e Tampa 22.264</p>	<p>V.E.</p>  <p>Trinco Inox FG 19mm com Chaves e Tampa 22.265</p>	 <p>Trinco Inox SR 25mm com Chave e Tampa 22.575 - 295 mm</p>	 <p>Trinco Inox SR 19mm sem Chave 22.558</p>

BANDEJAS

 <p>Bandeja Cinza 37.114 - com chave 37.242 - sem chave</p>	 <p>Bandeja Cinza Anti-Pânico 37.230 - com Chave 37.388 - sem Chave</p>	 <p>Bandeja Branca 37.289 - com chave 37.290 - sem chave</p>	 <p>Bandeja Branca Anti-Pânico 37.397 - com chave</p>
 <p>Bandeja Inox 37.624 - com chave 37.625 - sem chave</p>	 <p>Bandeja Inox Anti-pânico 37.283 - com chave 37.284 - sem chave</p>	 <p>Bandeja com Gatilho CV 22.119</p>	 <p>Bandeja com Trinco Articulado TPI FC - P * 22.385 - Int. ** 22.551 - Ext.</p>
 <p>Bandeja FC-RW TPI 22.709 - Branco 22.710 - Preto 22.711 - Cinza</p>	 <p>Trinco Bagageiro com Chave 37.154 - * Galvan. 37.286 - ** Branca 37.288 - *** Inox</p>	 <p>Trinco Interno da Kombi 37.153</p>	

Figuras e Fotos Meramente Ilustrativas.

RODOWESSLER

Site: www.rodowessler.com.br
e-mail: vendas@rodowessler.com.br

(11) 2431-5300



Peças para Implementos Rodoviários

RODOWESSLER[®]

REFERÊNCIA EM PEÇAS PARA IMPLEMENTOS

PORTAS PARA CARROCERIAS DE BEBIDAS



Na Rodowessler você encontra
Portas de Alumínio e a maior
variedade de acessórios
para a sua carroceria de Bebida.
Ligue (11) 2431-5300 e tenha a
segurança de receber seu produto
no menor prazo do mercado.

CARROCERIA PARA TRANSPORTE DE BEBIDAS

ANTONINI RODOFORT FACCHINI

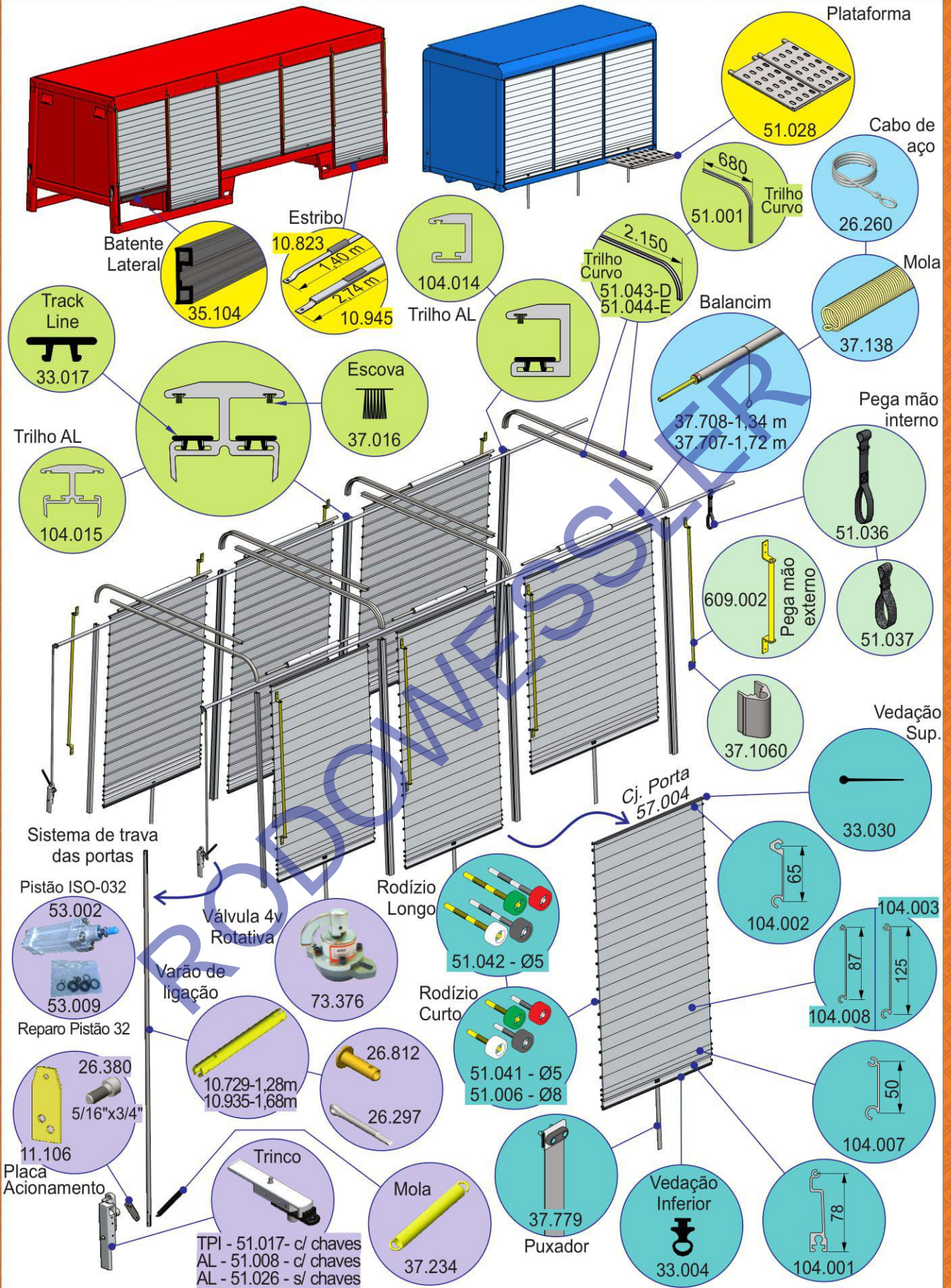

Figuras e Fotos Meramente Ilustrativas.

RODOWESSLER

Site: www.rodowessler.com.br
e-mail: vendas@rodowessler.com.br

(11) 2431-5300

068

Peças para Implementos Rodoviários



CARROCERIA PARA TRANSPORTE DE BEBIDAS

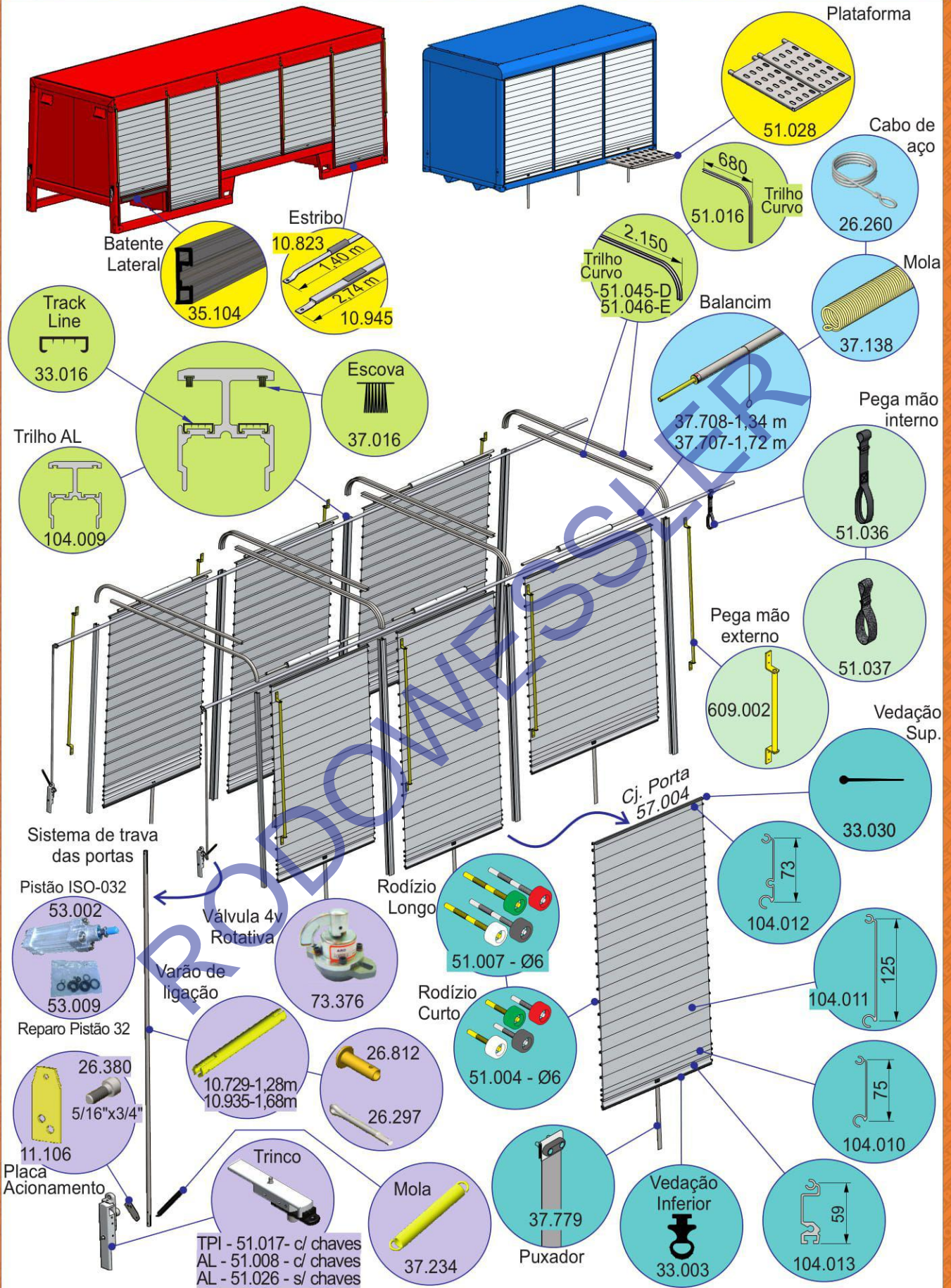

C
A
R
R
O
C
E
R
I
A

V
A
N

RODOWESSLER®

REFERÊNCIA EM PEÇAS PARA IMPLEMENTOS

BASES E SEUS ACESSÓRIOS



Pé Mecânico



Protetor Ciclista



Paralamas



Parachoques

Tudo o que você precisa
para reformar a base do
seu implemento, você
encontra na Rodowessler

Ligue (11)2431-5300

e **Solicite a compra**
de nossos produtos.

BASE - SÉRIE LEVE

M
U
L
T
I
M
A
R
C
A
S

Medidas da Base

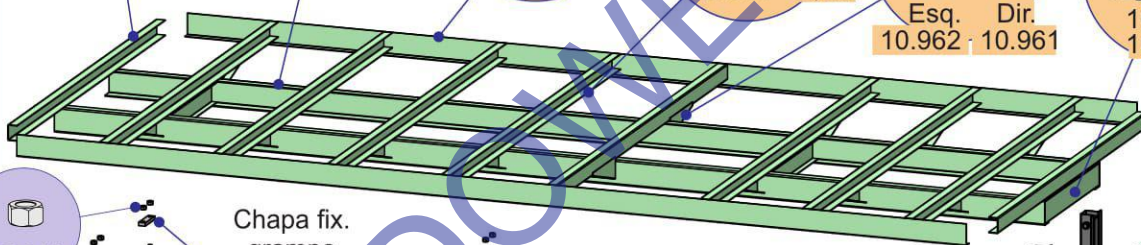
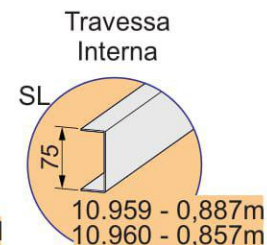
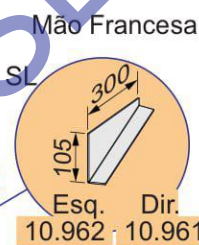
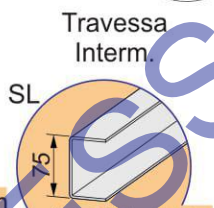
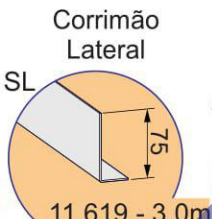
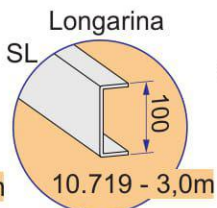
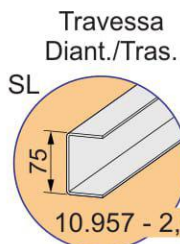
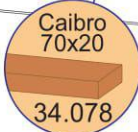
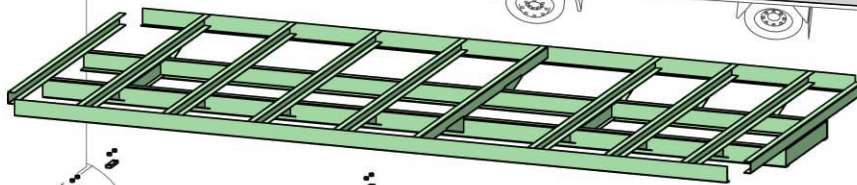
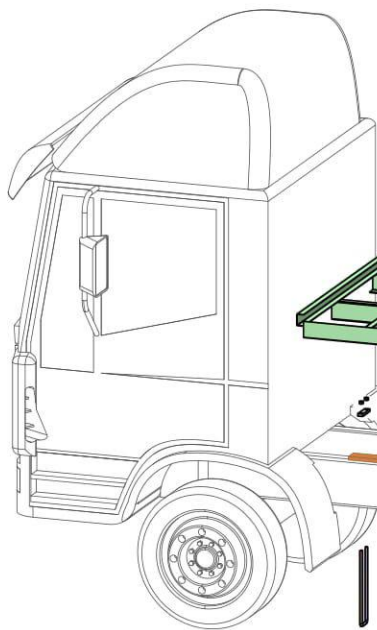
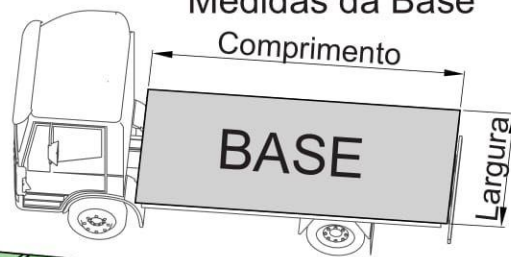

Parabarro

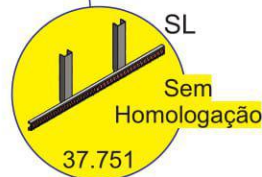
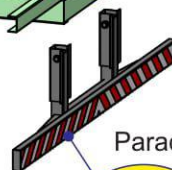
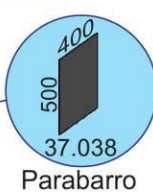
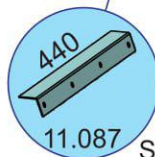
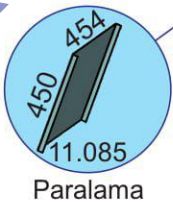
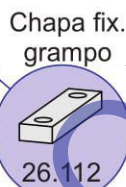

Grampos 5/8"unc x 92

- 26.093 - 300
- 26.094 - 320
- 26.095 - 340
- 26.097 - 360
- 26.098 - 380
- 26.099 - 400
- 26.100 - 420

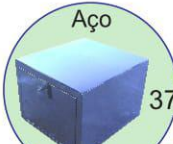

37.436 - A285 x L465 x P385

Altura x Largura x Profundidade

Figuras e Fotos Meramente Ilustrativas.

RODOWESSLER

Site: www.rodowessler.com.br
e-mail: vendas@rodowessler.com.br

(11) 2431-5300



Peças para Implementos Rodoviários

BASE - SÉRIE PESADA

Medidas da Base

Comprimento

Largura

BASE

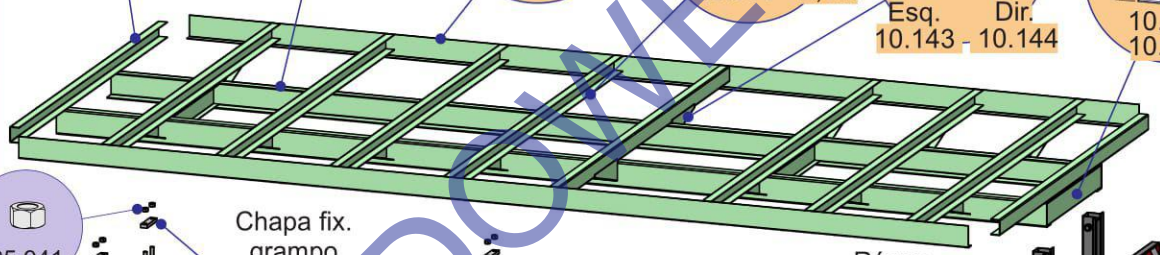
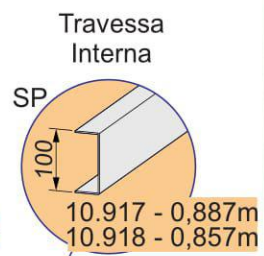
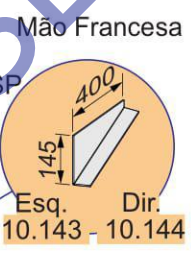
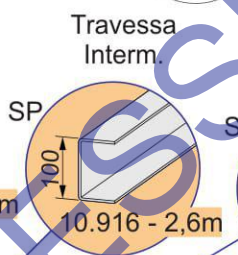
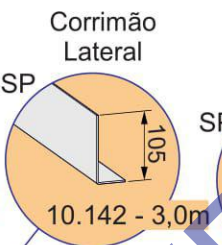
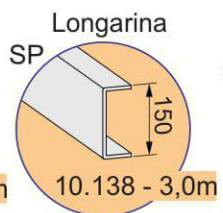
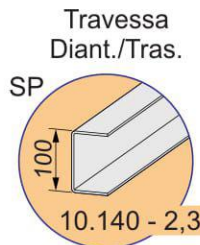
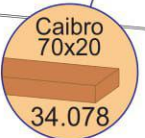
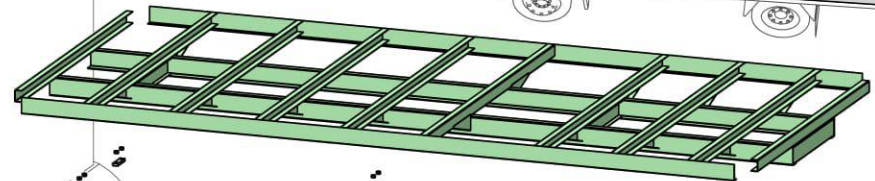
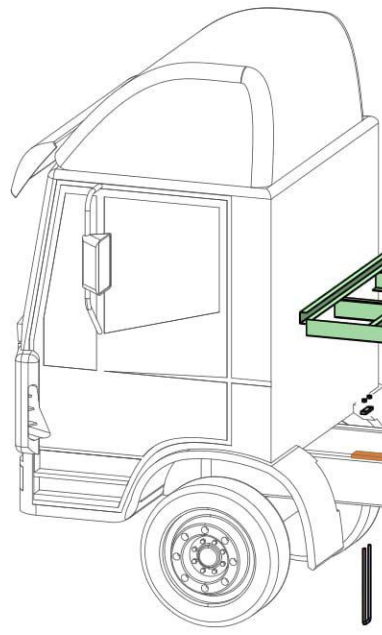

Parabarro

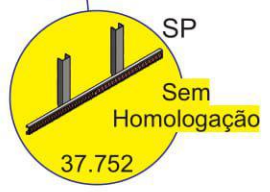
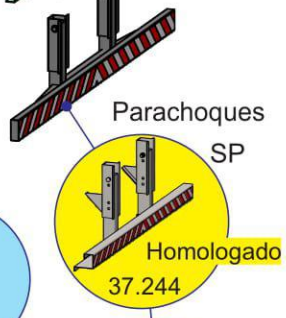
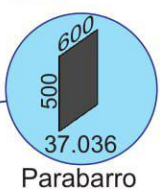
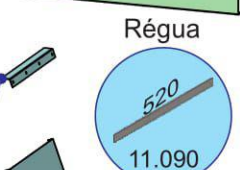
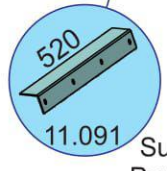
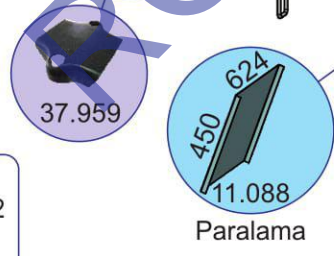
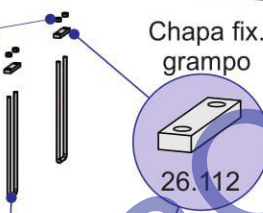

- Grampos 5/8"unc x 92
- 26.101 - 440
 - 26.103 - 460
 - 26.104 - 480
 - 26.105 - 500
 - 26.106 - 520
 - 26.107 - 540
 - 26.109 - 560

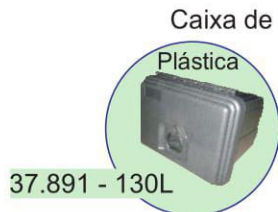

M
U
L
T
I
M
A
R
C
A
S



ACESSÓRIOS PARA SEMIRREBOQUES

M
U
L
T
I
M
A
R
C
A
S

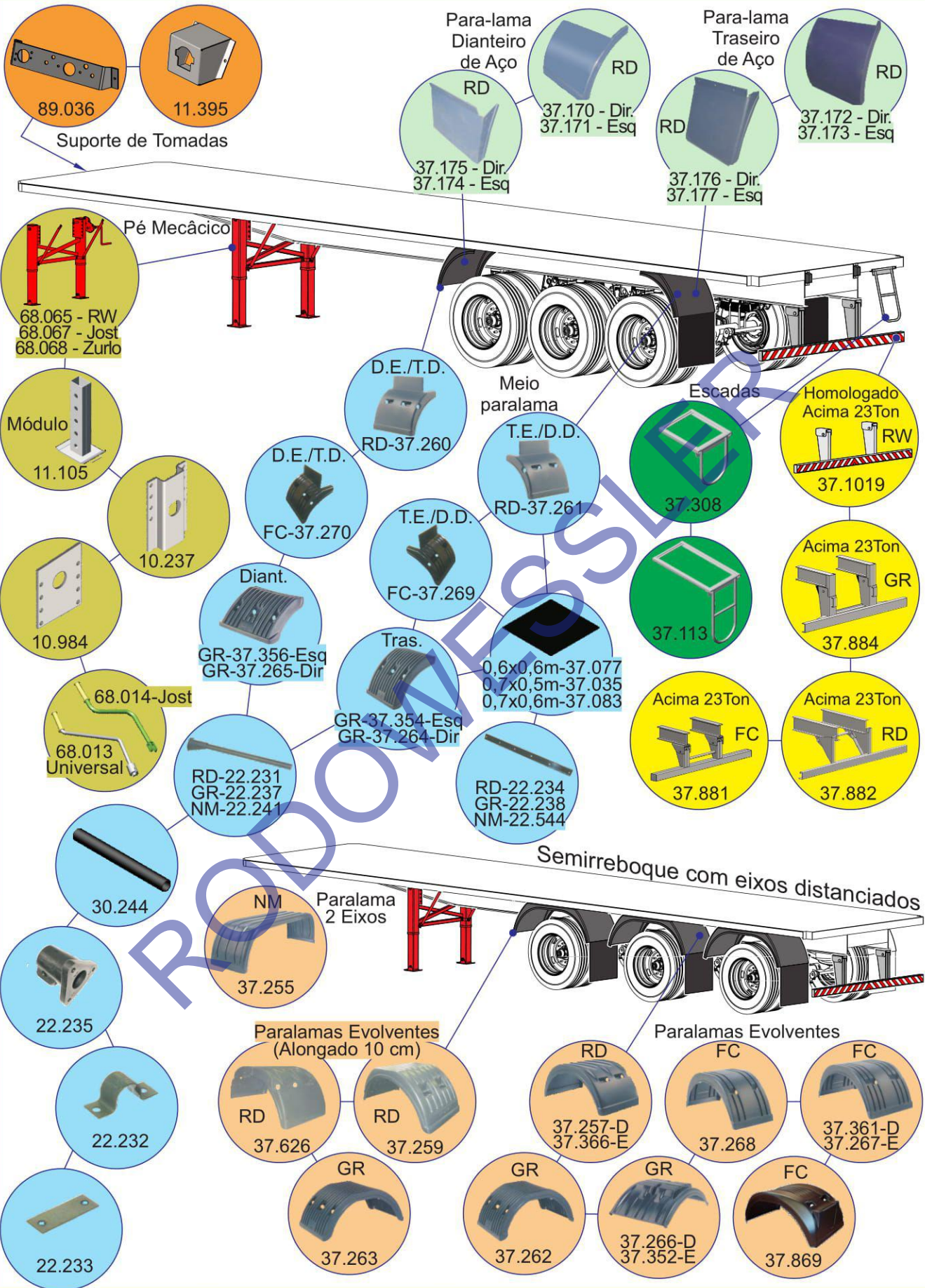

Figuras e Fotos Meramente Ilustrativas.

RODOWESSLER

Site: www.rodowessler.com.br
e-mail: vendas@rodowessler.com.br

(11) 2431-5300

074

Peças para Implementos Rodoviários



KIT MESA SEMIRREBOQUE

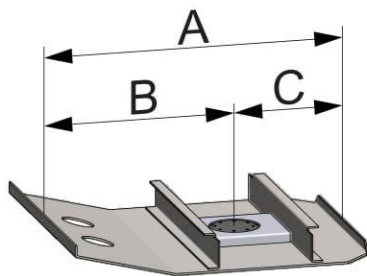

A = _____ mm
 B = _____ mm
 C = _____ mm
 D = _____ mm

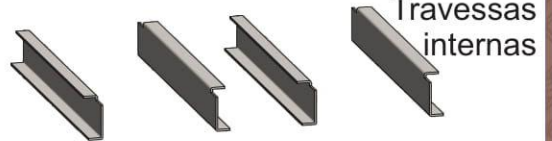

Travessas
internas



Reforço Base
Pino Rei

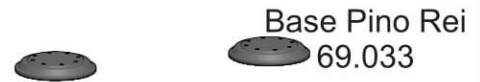

Base Pino Rei
69.033

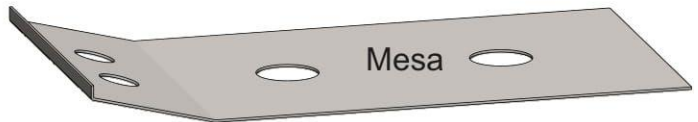

Mesa



Pino Rei
Flangeado
69.031

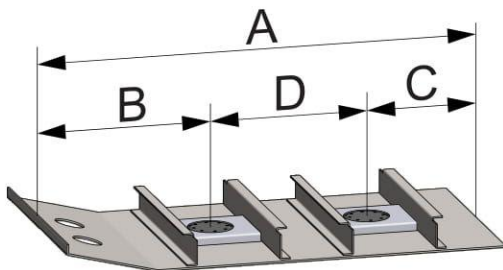

Conj. Mesa Inteiraça
Simples Inclinada
19.049

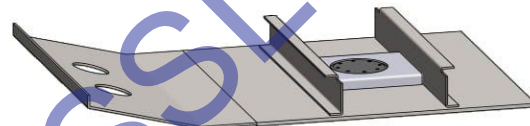

Conj. Mesa Segmentada
Simples Inclinada
19.050

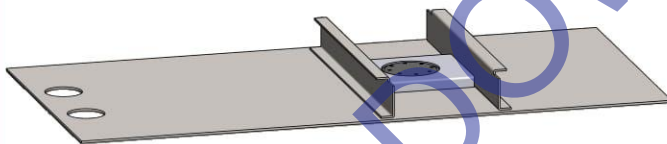

Conj. Mesa Inteiraça
Simples Reta
19.051

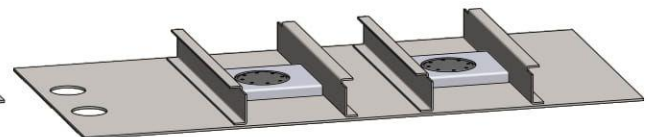

Conj. Mesa Inteiraça
Dupla Reta
19.052

Espelho
350x1000
11.186

Mesa
1000x1000
11.180

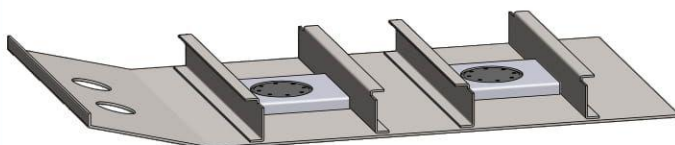

Conj. Mesa Inteiraça
Dupla Inclinada
19.053

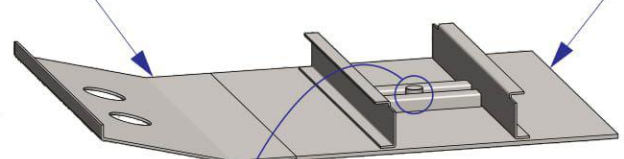

Pino Rei
Soldado

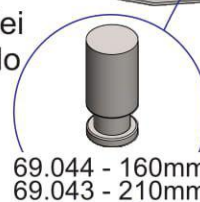

69.044 - 160mm
69.043 - 210mm

Conj. Mesa
Simples Inclinada
c/ Pino Rei Soldado
19.054

M
U
L
T
I
M
A
R
C
A
S

PROTETOR CICLISTA SEMIRREBOQUE

M
U
L
T
M
C
A
R
C
A
S

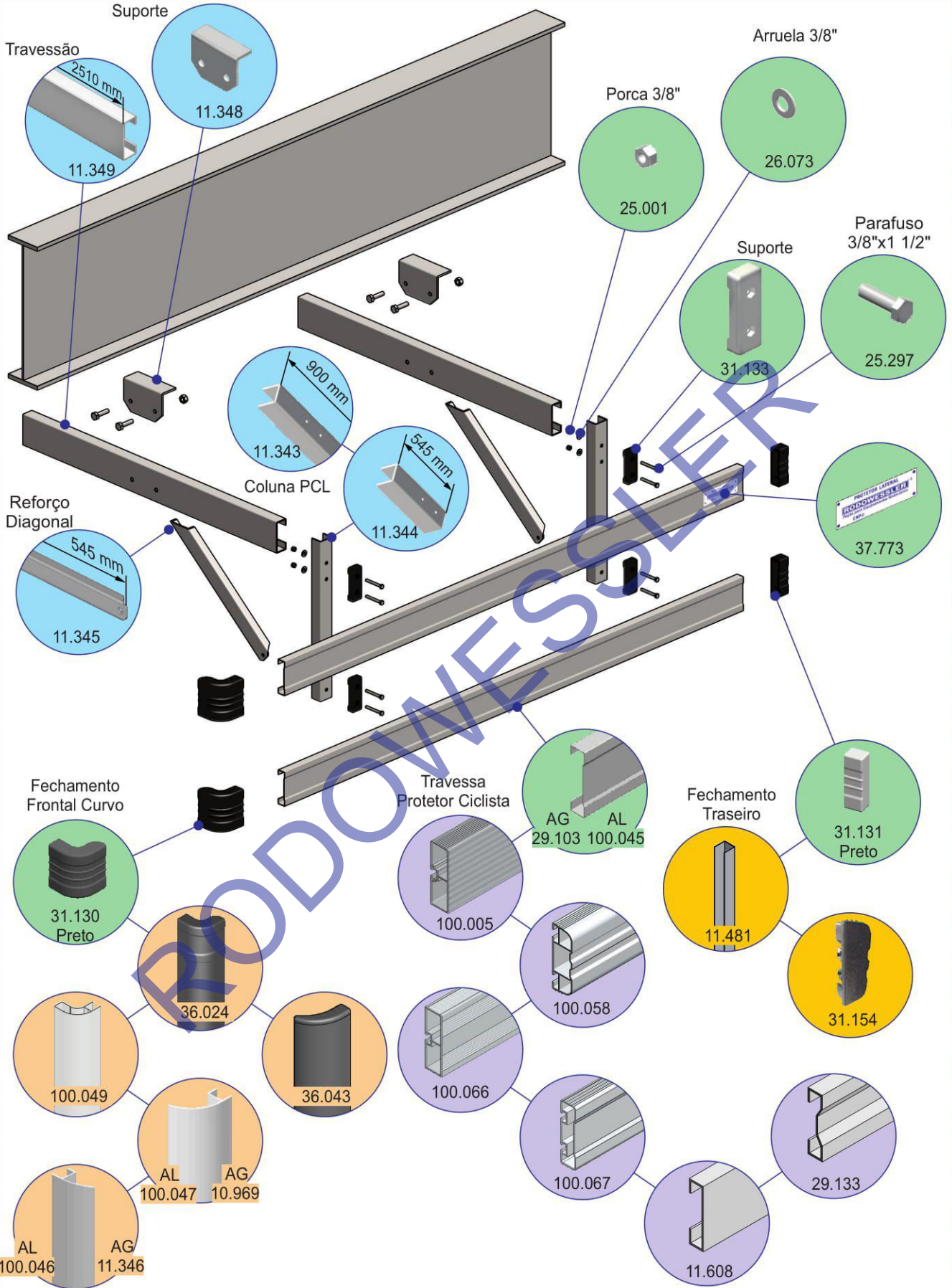

RODOWESSLER[®]

REFERÊNCIA EM PEÇAS PARA IMPLEMENTOS

CARGA SECA E GRANELEIRO



A Rodowessler trabalha para atender os diversos setores de implementos rodoviários.

Ligue (11)2431-5300
e **descubra os produtos**
que podemos oferecer.



KIT CARGA SECA SL

M
U
L
T
I
M
A
R
C
A
S

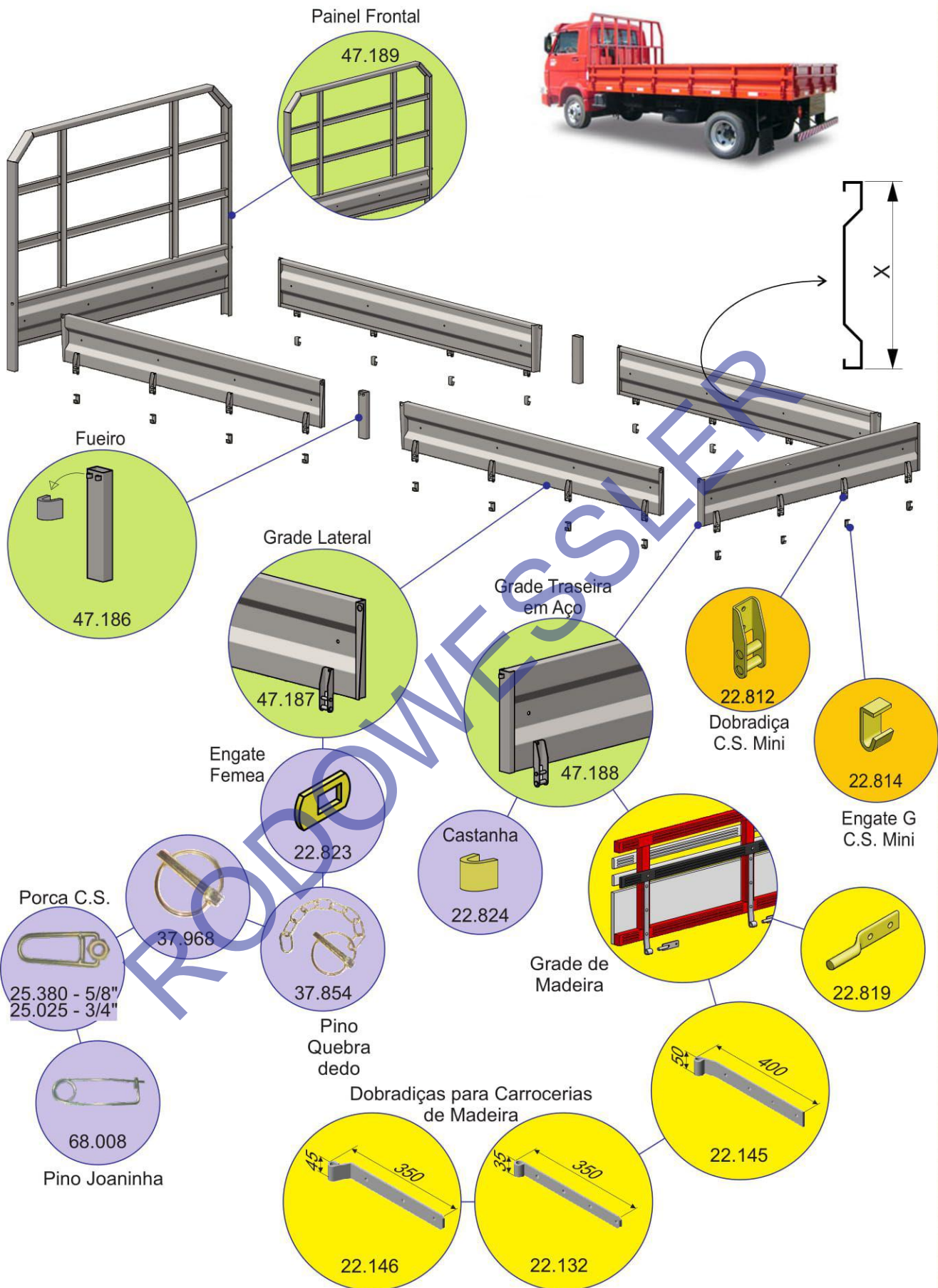

ACESSÓRIOS CARGA SECA SP E GRANELEIRO

M
U
L
T
M
A
R
C
A
S

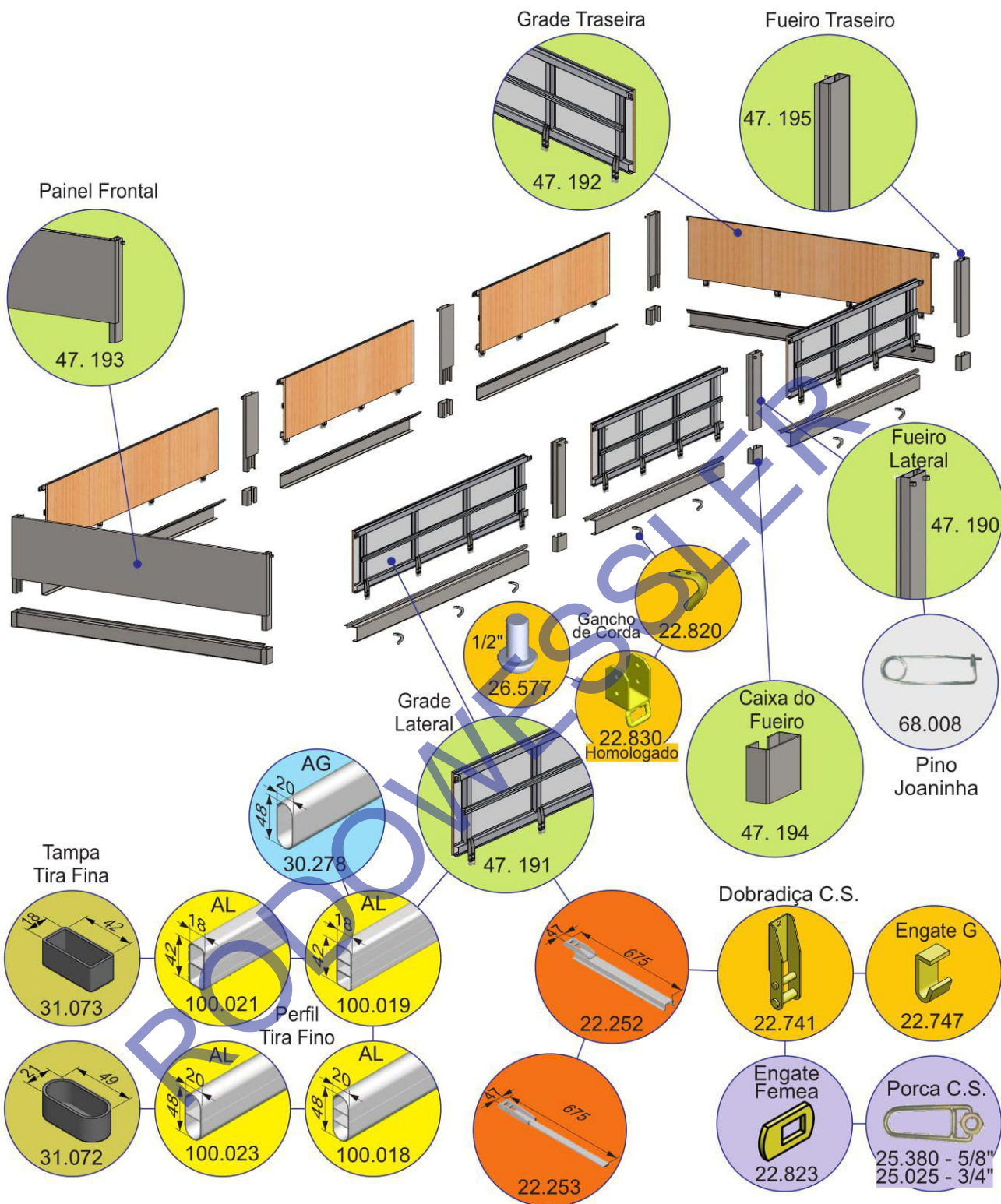

Figuras e Fotos Meramente Ilustrativas.

RODOWESSLER

Peças para Implementos Rodoviários

Site: www.rodowessler.com.br
e-mail: vendas@rodowessler.com.br

(11) 2431-5300



ACESSÓRIOS PARA AMARRAÇÃO DE CARGA

M
U
L
T
I
M
A
R
C
A
S

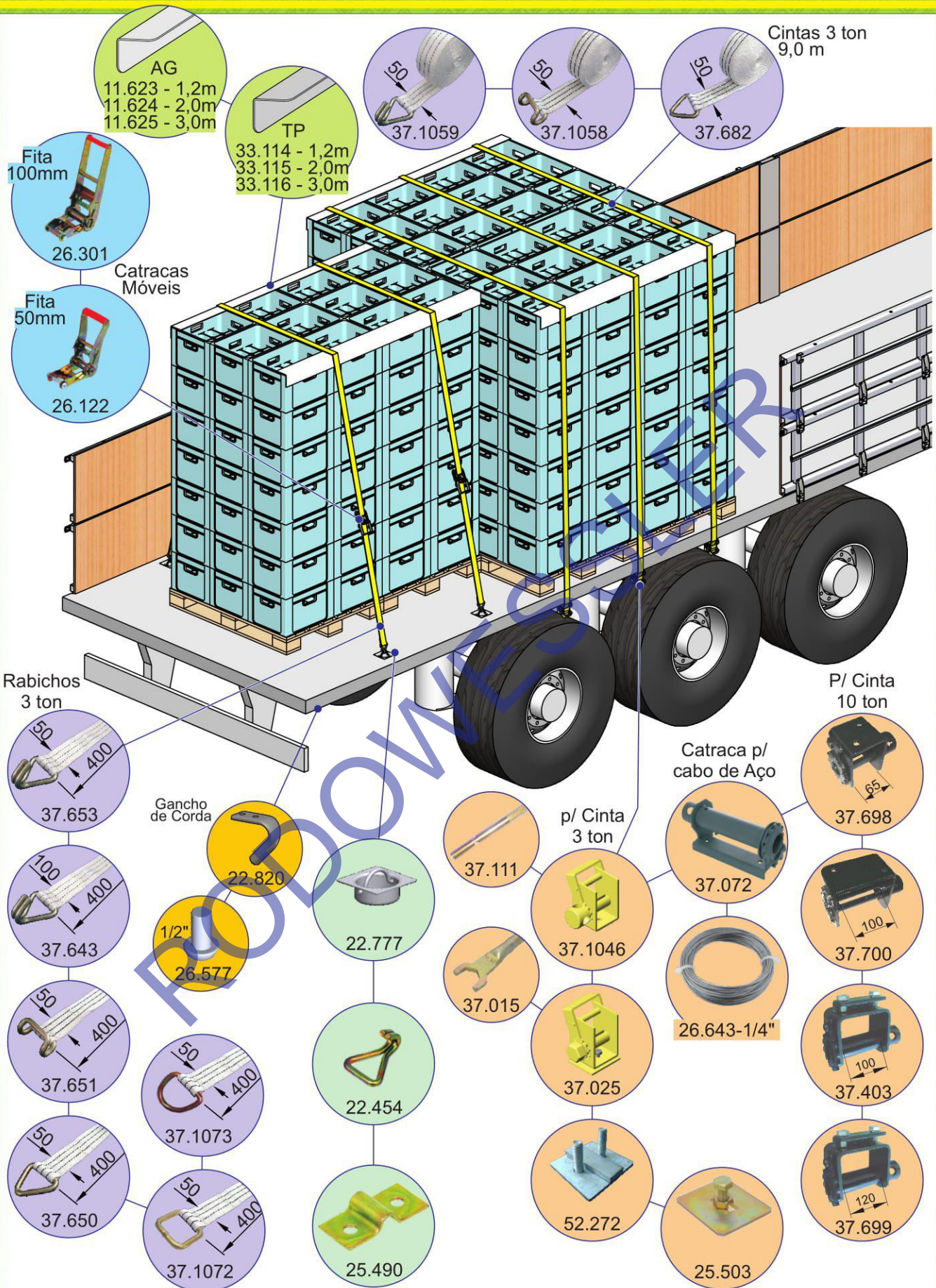

AG
11.623 - 1,2m
11.624 - 2,0m
11.625 - 3,0m

TP
33.114 - 1,2m
33.115 - 2,0m
33.116 - 3,0m

50
37.1059

50
37.1058

50
37.682

Cintas 3 ton
9,0 m

Fita 100mm
26.301

Fita 50mm
26.122

Catracas Móveis

Rabichos 3 ton

50 400
37.653

100 400
37.643

50 400
37.651

50 400
37.650

Gancho de Corda
22.820

1/2"
26.577

50 400
37.1073

50 400
37.1072

22.777

22.454

25.490

37.111

37.015

p/ Cinta 3 ton
37.1046

37.025

52.272

Catraca p/ cabo de Aço

37.072

26.643-1/4"

52.272

25.503

P/ Cinta 10 ton

65
37.698

100
37.700

100
37.403

120
37.699

Figuras e Fotos Meramente Ilustrativas



ELEMENTOS DE FIXAÇÃO

REBITE POP 3/16" = 5mm

- 25.010 - 510 = 3/16" x 3/8"
- 25.002 - 512 = 3/16" x 1/2"
- 25.034 - 514 = 3/16" x 9/16"
- 25.035 - 516 = 3/16" x 5/8"
- 25.036 - 519 = 3/16" x 3/4"
- 25.037 - 522 = 3/16" x 7/8"
- 25.038 - 525 = 3/16" x 1"
- 25.039 - 530 = 3/16" x 1.3/16"
- 25.040 - 535 = 3/16" x 1.3/8"
- 25.041 - 540 = 3/16" x 1.9/16"



REBITE POP 1/4" = 6mm

- 25.042 - 610 = 1/4" x 3/8"
- 25.043 - 612 = 1/4" x 1/2"
- 25.044 - 614 = 1/4" x 9/16"
- 25.045 - 616 = 1/4" x 5/8"
- 25.046 - 619 = 1/4" x 3/4"
- 25.047 - 622 = 1/4" x 7/8"
- 25.048 - 625 = 1/4" x 1"
- 25.049 - 630 = 1/4" x 1.3/16"
- 25.050 - 635 = 1/4" x 1.3/8"
- 25.051 - 640 = 1/4" x 1.9/16"
- 25.022 - 616 E = 1/4" x 5/8" aba larga
- 25.098 - 619 E = 1/4" x 3/4" aba larga
- 25.099 - 625 E = 1/4" x 1" aba larga



REBITE MACIÇO (lentilha)

- 25.070 - 3/16" x 3/8"
- 25.003 - 3/16" x 1/2"
- 26.188 - 3/16" x 5/8"
- 26.119 - 1/4" x 1/2"
- 26.120 - 1/4" x 5/8"



GRAMPOS P/ BAÚS

- 26.089 - 5/8"x82x200-unc
- 26.090 - 5/8"x92x250-unc
- 26.775 - 5/8"x92x260-unc
- 26.776 - 5/8"x92x280-unc

- 26.093 - 5/8"x92x300-unc
- 26.094 - 5/8"x92x320-unc
- 26.095 - 5/8"x92x340-unc
- 26.384 - 5/8"x82x380-unc

- 26.097 - 5/8"x92x360-unc
- 26.098 - 5/8"x92x380-unc
- 26.099 - 5/8"x92x400-unc
- 26.100 - 5/8"x92x420-unc

- 26.101 - 5/8"x92x440-unc
- 26.103 - 5/8"x92x460-unc
- 26.104 - 5/8"x92x480-unc
- 26.105 - 5/8"x92x500-unc

- 26.106 - 5/8"x92x520-unc
- 26.107 - 5/8"x92x540-unc
- 26.780 - 5/8"x92x550-unc
- 26.109 - 5/8"x92x560-unc



- 26.110 - 5/8"x92x600-unc
- 26.111 - Chapa fix.Grampo 5/8"
- 26.112 - Chapa fix.Grampo 1/2"
- 25.941 - Porca Sext. 5/8"
- *37.959 - Chapa fix. tipo Concha

ARRUELA LISA

- 26.071 - 1/4"
- 26.072 - 5/16"
- 26.073 - 3/8"
- 26.075 - 1/2"
- 26.218 - 13 x 6,4 x 1



ARRUELA DE PRESSÃO

- 26.053 - 1/4"
- 26.054 - 5/16"
- 26.055 - 3/8"
- 26.057 - 1/2"



PORCAS

- 25.090 - Alto Travante 1/4" NF
- 25.094 - Alto Travante 5/16" NF
- 25.001 - Alto Travante 3/8" NF

- 26.128 - 1/4" NC
- 25.947 - 1/4" NF

- 25.936 - 5/16" NC
- 25.948 - 5/16" NF

- 25.937 - 3/8" NC
- 25.949 - 3/8" NF

- 25.939 - 1/2" NC
- 25.951 - 1/2" NF

- 25.941 - 5/8" NC
- 25.979 - Alto Travante 1/4" NC
- 25.980 - Alto Travante 5/16" NC
- 25.981 - Alto Travante 3/8" NC



PARAFUSO FRANCÊS

- 25.107 - 1/4" x 1" NC ZC
- 25.108 - 1/4" x 1.1/4" NC
- 25.109 - 1/4" x 1.1/2" NC
- 25.111 - 1/4" x 2" NC
- 25.113 - 1/4" x 2.1/2" NC
- 25.115 - 1/4" x 3" NC

- 25.121 - 5/16" x 1" NC
- 25.123 - 5/16" x 1.1/2" NC
- 25.125 - 5/16" x 2" NC
- 25.127 - 5/16" x 2.1/2" NC
- 25.129 - 5/16" x 3" NC
- 25.152 - 5/16" x 3.1/2" NC

PARAFUSOS BROCANTES

- 26.805 - M 4,3 x 13
- 25.543 - M 5 x 45
- 25.538 - M 5 x 50



PARAFUSO SEXTAVADO



- 25.288 - 1/4" x 3/4" NF ZB
- 25.227 - 1/4" x 1" NC ZB
- 25.289 - 1/4" x 1" NF ZB
- 25.290 - 1/4" x 1 1/2" NF ZB
- 25.231 - 1/4" x 2" NC ZB
- 25.232 - 1/4" x 2 1/2" NC ZB

- 25.241 - 5/16" x 2" NC RI ZB
- 26.129 - 5/16" x 2" NC RI
- 25.330 - 5/16" x 2 1/2" NC RP
- 25.332 - 5/16" x 3" NC RP
- 25.333 - 5/16" x 3 1/2" NC RP

- 25.250 - 3/8" x 1" NC RI
- 26.130 - 3/8" x 1" NC ZC RI ZB
- 25.000 - 3/8" x 1" NF ZC RI ZB
- 25.297 - 3/8" x 1 1/2" NF ZC ZB
- 25.254 - 3/8" x 2" NC RI ZB
- 25.341 - 3/8" x 2 1/2" NC RD
- 25.342 - 3/8" x 3" NF RI

- 26.131 - 1/2" x 1 1/2" NC RP
- 25.268 - 1/2" x 1 3/4" NC RI
- 25.269 - 1/2" x 2" NC RI
- 25.270 - 1/2" x 2 1/2" NC RI
- 25.271 - 1/2" x 3" NC RI
- 25.363 - 1/2" x 3 1/2" NC RI



M
U
L
T
I
M
A
R
C
A
S

ACESSÓRIOS ELÉTRICOS

M
U
L
T
I
M
A
R
C
A
S

<p>E</p>  <p>Lanterna Retangular Lateral GF-110 50.066 - Cristal 50.064 - Amarela 50.065 - Vermelha</p>	 <p>Lente Retangular Lateral GF-030 50.184 - Cristal 50.149 - Amarela 50.183 - Vermelha</p>	 <p>Lanterna Topo GF-121 50.075 - Cristal 50.002 - Amarela 50.003 - Vermelha</p>	 <p>Lente Topo GF-043 50.222 - Cristal 50.127 - Amarela 50.161 - Vermelha</p>
 <p>Lanterna Topo GF-214 50.093 - Cristal 50.006 - Amarela 50.092 - Vermelha</p>	 <p>Lente Topo GF-032 50.243 - Cristal 50.129 - Amarela 50.151 - Vermelha</p>	 <p>Lanterna Topo GF-212 50.005 - Cristal 50.090 - Amarela 50.004 - Vermelha</p>	 <p>Lente Topo GF-028 50.128 - Cristal 50.242 - Amarela 50.148 - Vermelha</p>
<p>B</p>  <p>Lanterna Traseira GF-206 50.088 - Cristal Lente Traseira GF-017 50.228 - Cristal</p>	 <p>Lanterna de Placa mod. Novo 50.316</p>	 <p>Lâmpada 69 50.169 - 12v - 5w 50.260 - 24v - 5w</p>	<p>B E</p>  <p>Lâmpada 67 50.255 - 12v - 4w 50.254 - 24v - 4w</p>
<p>C D</p>  <p>Lâmpada 1141 1 polo 50.179 - 12v - 21w 50.177 - 24v - 21w</p>	<p>C D</p>  <p>Lâmpada 1034 2 Polos Pino Desencontrado 50.346 - 12v-21/5w 50.347 - 24v-21/5w</p>	<p>C D</p>  <p>Lâmpada 1176 2 Polos Pino Encontrado 50.275 - 12v-21-5w 50.276 - 24v-21-5w</p>	 <p>Cabo Chicote 7 Fios - 1,0 mm 50.1149 - 1,0 m</p>
 <p>Fio Cabinho 1mm 50.244 - Preto 50.324 - Vermelho 50.325 - Amarelo</p>	 <p>Presilha p/ Fixação chicote 26.222 - 40 mm 26.223 - 55 mm</p>		

Figuras e Fotos Meramente Ilustrativas.

RODOWESSLER

Site: www.rodowessler.com.br
e-mail: vendas@rodowessler.com.br

(11) 2431-5300

082

Peças para Implementos Rodoviários



Conheça a Rodowessler e saiba como podemos melhor atendê-lo.



Faixa da Fábrica Rodowessler



Fábrica Rodowessler



Fábrica Rodowessler



Frisagem de chapas



Perfilção



Estoque de Peças



Estoque de Perfis



Estamparia



Ferramentaria



Corte & Dobra



Injeção Termoplástica



Soldagem



Extrusão Termoplástica



Usinagem



Fabricação de Portas



Confeccção de Lonas

O parque industrial da Rodowessler é um dos mais completos dentro do setor de implementos rodoviários, tudo isso visando atender o cliente com qualidade, pronta entrega e maior disponibilidade de produtos.

RODOWESSLER[®]

REFERÊNCIA EM PEÇAS PARA IMPLEMENTOS

Atendemos a toda América do Sul



Representante

Acesse nosso site:
www.rodowessler.com.br

RODOWESSLER PEÇAS E SERVIÇOS EIRELI.

Av. Papa João Paulo I, nº 1715 - Vila Aeroporto - CEP: 07170-350 - Guarulhos - SP - Brasil

vendas@rodowessler.com.br - rodowessler@rodowessler.com.br

Fone: (55) (11) 2431.5300 - Fax: (55) (11) 2431.5305